

MULTI SPLIT

MULTI ZONE WALL MOUNTED INDOOR UNIT

Model: LBHB09DUI

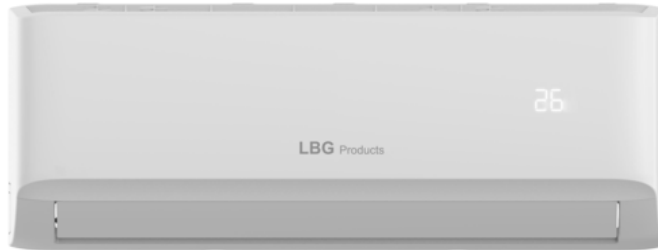

Item	Unit	Parameter
Model	—	LBHB09DUI
Performance		
Rated Cooling Capacity (Range)	Btu/h	9000(3700~13300)
EER	Btu/w	15.8
SEER	Btu/w	25.5
Rated Heating Capacity (Range)	Btu/h	12000(5100~14300)
COP	W/W	3.9
HSPF4	Btu/w	12.5
Electrical Data		
Normal Operational Voltage	V, Ph, Hz	208/230, 1, 60
Voltage Range	V	187-253
MCA	A	
MOP	A	15
Indoor fan motor		
Type	—	Cross-Flow
Model	—	ZKFP-13-8-4
Qty	—	1
Speed(Hi/Mi/Lo)	r/min	1150/990/750
Air flow & Noise level		
Indoor air flow (Hi/Med/Lo) (No duct)	CFM	495/330/260
Indoor noise level (Hi/Med/Lo)	dB(A)	40/35/23.5
Dimension & Weight		
Dimension (WxDxH)	inch	31.57×7.87×11.61
	mm	802×200×295
Packing(WxDxH)	inch	34.45×11.22×14.96
	mm	875×285×380
Net/Gross weight	lbs.	18.96/24.25
	kg	8.6/11
Others		
Liquid side/ Gas side	inch	1/4" / 3/8"
	mm	Φ6.35 / Φ9.52
Application area	sq.ft	129.17 ~ 193.75
	m2	12 ~ 18

Job Name:

Schedule Reference:

Date:

Specification are subject to change without notice.

Outline and Physical Dimensions of LBHB09DUI

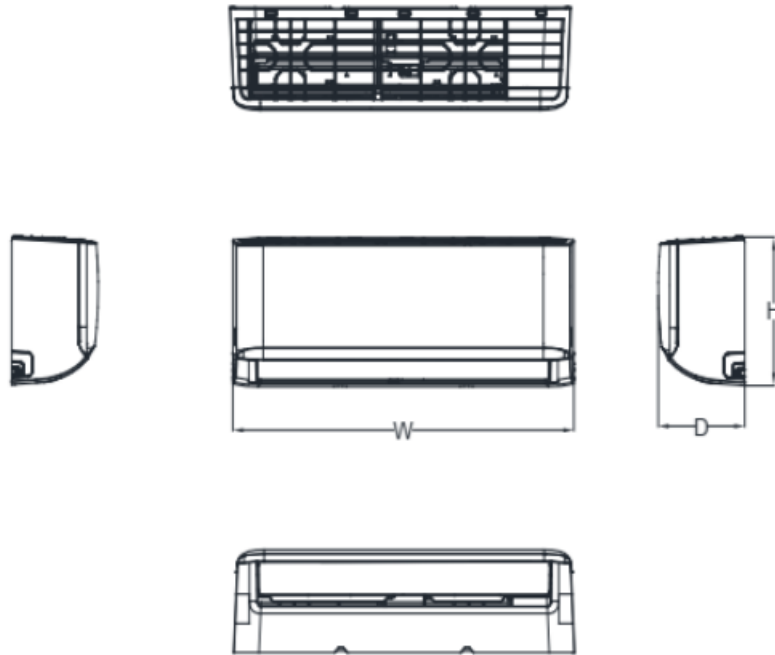

Model	W(mm/inch)	D(mm/inch)	H(mm/inch)
LBHB09DUI	802/31.57	200/7.87	295/11.61

The Installation of the Rear Panel

