

MULTI SPLIT

MULTI ZONE WALL MOUNTED INDOOR UNIT

Model: LBHB24DUI



| Item | Unit | Parameter |
|---------------------------------------|-----------|-------------------|
| Model | — | LBHB24DUI |
| Performance | | |
| Rated Cooling Capacity (Range) | Btu/h | 23000(4650~26600) |
| EER | Btu/w | 12.5 |
| SEER | Btu/w | 21.5 |
| Rated Heating Capacity (Range) | Btu/h | 26000(9550~27000) |
| COP | W/W | 3 |
| HSPF4 | Btu/w | 11.5 |
| Electrical Data | | |
| Normal Operational Voltage | V, Ph, Hz | 208/230, 1, 60 |
| Voltage Range | V | 187-253 |
| MCA | A | |
| MOP | A | 15 |
| Indoor fan motor | | |
| Type | — | Cross-Flow |
| Model | — | ZKFP-58-8-1-5 |
| Qty | — | 1 |
| Speed(Hi/Mi/Lo) | r/min | 1200/1080/600 |
| Air flow & Noise level | | |
| Indoor air flow (Hi/Med/Lo) (No duct) | CFM | 1022/780/650 |
| Indoor noise level (Hi/Med/Lo) | dB(A) | 46.5/44/35 |
| Dimension & Weight | | |
| Dimension (W×D×H) | inch | 42.60×9.21×13.27 |
| | mm | 1082×234×337 |
| Packing(W×D×H) | inch | 45.47×16.34×12.40 |
| | mm | 1155×415×315 |
| Net/Gross weight | lbs. | 29.98/38.14 |
| | kg | 13.6/17.3 |
| Others | | |
| Liquid side/ Gas side | inch | 3/8" / 5/8" |
| | mm | Φ9.52 / Φ15.9 |
| Application area | sq.ft | 333.68 ~ 484.38 |
| | m2 | 31 ~ 45 |

Job Name:

Schedule Reference:

Date:

Specification are subject to change without notice.

Outline and Physical Dimensions of LBHB24DUI

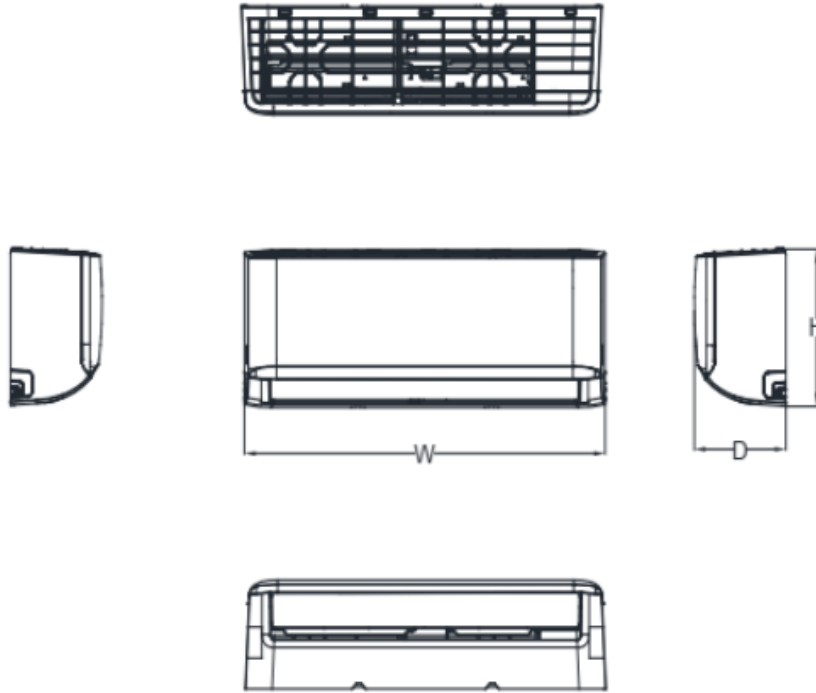

| Model | W(mm/inch) | D(mm/inch) | H(mm/inch) |
|-----------|------------|------------|------------|
| LBHB24DUI | 1082/42.60 | 234/9.21 | 337/13.27 |

The Installation of the Rear Panel

