



# **Owner's Manual**

## **Original Instructions**

Commercial Air Conditioners

### **AHU-KIT**

Models:

GMV-N12U/C-T(U)

GMV-N24U/C-T(U)

GMV-N48U/C-T(U)

GMV-N96U/C-T(U)

GMV-N192U/C-T(U)

Thank you for choosing commercial air conditioners. Please read this Owner's Manual carefully before operation and retain it for future reference.

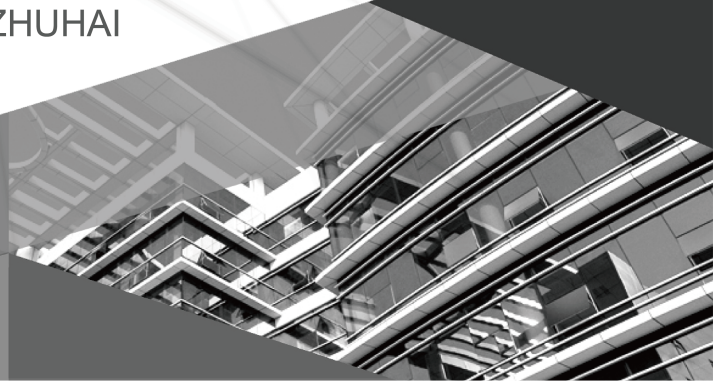

If you have lost the Owner's Manual, please contact the local agent or visit [www.gree.com](http://www.gree.com) or send an email to [global@cn.gree.com](mailto:global@cn.gree.com) for the electronic version.

**GREE ELECTRIC APPLIANCES, INC. OF ZHUHAI**



## Preface

For correct installation and operation, please read all instructions carefully. Before reading the instructions, please be aware of the following items:

 <b>DANGER</b>	This is the safety alert symbol. It is used to alert you to potential personal injury hazards. Obey all safety messages that follow this symbol to avoid possible injury or death.
 <b>WARNING</b>	This mark indicates procedures which, if improperly performed, might lead to the death or serious injury of the user.
 <b>CAUTION</b>	This mark indicates procedures which, if improperly performed, might possibly result in personal harm to the user, or damage to property.
<b>NOTICE</b>	NOTICE is used to address practices not related to personal injury.

 <b>WARNING</b>	
(1)	Instructions for installation and use of this product are provided by the manufacturer.
(2)	Installation must be performed in accordance with the requirements of NEC and CEC by authorized personnel only.
(3)	For the safe operation of this unit, please read and follow the instructions carefully.
(4)	During operation, total capacity of indoor units should not exceed the total capacity of outdoor units. Otherwise, poor effect of cooling or heating may result.
(5)	Direct operators or maintainers should well keep this manual.
(6)	If this unit fails to operate normally, please contact our service center as soon as possible and provide the following information: 1) Content on the nameplate (model number, cooling capacity, production code, ex-factory date). 2) Malfunction details (before and after the malfunction occurs).
(7)	Each unit has been strictly tested and proved to be qualified before ex-factory. In order to prevent units from being damaged or operating normally because of improper disassembly, please do not disassemble the unit by yourself. If you need to disassemble and check units, please contact our service center. We will send specialists to guide the disassembly.

This appliance can be used by children aged from 8 years and above and persons with reduced physical, sensory or mental capabilities or lack of experience and knowledge if they have been given supervision or instruction concerning use of the appliance in a safe way and understand the hazards involved. Children shall not play with the appliance. Cleaning and user maintenance shall not be made by children without supervision.



**DISPOSAL:** Do not dispose this product as unsorted municipal waste. Collection of such waste separately for special treatment is necessary.



## Exception Clauses

Manufacturer will bear no responsibilities when personal injury or property loss is caused by the following reasons:

(1) Damage the product due to improper use or misuse of the product;

(2) Alter, change, maintain or use the product with other equipment without abiding by the instruction manual of manufacturer;

(3) After verification, the defect of product is directly caused by corrosive gas;

(4) After verification, defects are due to improper operation during transportation of product;

(5) Operate, repair, maintain the unit without abiding by instruction manual or related regulations;

(6) After verification, the problem or dispute is caused by the quality specification or performance of parts and components that produced by other manufacturers;

(7) The damage is caused by natural calamities, bad using environment or force majeure.

# Contents

1 Safety Precautions.....	1
2 Product Introduction.....	2
2.1 Names of Key Components .....	2
2.2 Overall System Connection Diagram.....	2
2.3 Standard Fittings .....	3
2.4 Specifications.....	4
2.5 Recommended Selection of Air Handling Unit .....	6
3 Preparations for Installation .....	10
3.1 Before Installation .....	10
3.2 Location for Installation .....	11
3.3 Requirements for Communication Wire .....	12
3.4 Wiring Requirements .....	14
3.5 Piping Requirements .....	14
3.6 Capacity Setting.....	17
4 Installation Instructions .....	18
4.1 Unit Dimensions and Maintenance Space.....	18
4.2 EXV Installation .....	21
4.3 Installation of the EXV Cable .....	24
4.4 Piping Installation.....	24
4.5 Installation of the Control Box.....	26
4.6 Installation of the Temperature Sensors .....	28
4.7 Installation of Wired Controller .....	31
5 Wire Connection .....	32
5.1 Connect Cables and Terminals of Wiring Board.....	32
5.2 Power Cord Connection.....	33
5.3 Connection of Communication Wire between Indoor Unit and Outdoor Unit (or Indoor Unit) .....	34
5.4 Connect Communication Wire of Wired Controller .....	35
5.5 Illuminate for Connection of Wired Controller and Indoor Units (AHU-KIT) Network.....	35
6 Function Setting.....	37
6.1 Statement on Linkage Function Setting .....	37
6.2 Fresh air Function Setting .....	37
6.3 Selection of Controller.....	39
7 Operation and Maintenance .....	45
7.1 Before Operation.....	45
7.2 Test Operation .....	45
7.3 Routine Maintenance.....	46
7.4 Disposal Requirements.....	46
8 Table of Error Codes for Indoor Unit.....	47
9 Troubleshooting .....	48

# 1 Safety Precautions

 <b>WARNING</b>
(1) This product can't be installed at corrosive, inflammable or explosive environment or the place with special requirements, such as kitchen. Otherwise, it will affect the normal operation or shorten the service life of the unit, or even cause fire hazard or serious injury. As for above special places, please adopt special air conditioner with anti-corrosive or anti-explosion function.
(2) Follow this instruction to complete the installation work. Please carefully read this manual before unit startup and service.
(3) Wire size of power cord should be large enough. The damaged power cord and connection wire should be replaced by exclusive cable.
(4) After connecting the power cord, please fix the electric box cover properly in order to avoid accident.
(5) Never fail to comply with the nitrogen charge requirements. Charge nitrogen when welding pipes.
(6) Never short-circuit or cancel the pressure switch to prevent unit damage.
(7) Please firstly connect the wired controller before energization, otherwise wired controller can't be used.
(8) Before using the unit, please check if the piping and wiring are correct to avoid water leakage, refrigerant leakage, electric shock, or fire etc.
(9) Do not insert fingers or objects into air outlet/inlet grille.
(10) Open the door and window and keep good ventilation in the room to avoid oxygen deficit when the gas/oil supplied heating equipment is used.
(11) Never start up or shut off the air conditioner by means of directly plug or unplug the power cord.
(12) Turn off the unit after it runs at least five minutes; otherwise it will influence oil return of the compressor.
(13) Do not allow children operate this unit.
(14) Do not operate this unit with wet hands.
(15) Turn off the unit or cut off the power supply before cleaning the unit, otherwise electric shock or injury may happen.
(16) Never spray or flush water towards unit, otherwise malfunction or electric shock may happen.
(17) Do not expose the unit to the moist or corrosive circumstances.
(18) Under cooling mode, please don't set the room temperature too low and keep the temperature difference between indoor and outdoor unit within 5°C(41°F).
(19) User is not allowed to repair the unit. Fault service may cause electric shock or fire accidents. Please contact Gree appointed service center for help.
(20) Before installation, please check if the power supply is in accordance with the requirements specified on the nameplate. And also take care of the power safety.
(21) Installation should be conducted by dealer or qualified personnel. Please do not attempt to install the unit by yourself. Improper handling may result in water leakage, electric shock or fire disaster etc.
(22) The control box should be installed inside
(23) Be sure to use the exclusive accessory and part to prevent the water leakage, electric shock and fire accidents.
(24) Make sure the unit can be earthed properly and soundly after plugging into the socket so as to avoid electric shock. Please do not connect the ground wire to gas pipe, water pipe, lightning rod or telephone line.
(25) Electrify the unit 8 hours before operation. Please switch on for 8 hours before operation. Do not cut off the power when 24 hours short-time halting (to protect the compressor).
(26) If refrigerant leakage happens during installation, please ventilate immediately. Poisonous gas will emerge if the refrigerant gas meets fire.
(27) Volatile liquid, such as diluent or gas will damage the unit appearance. Only use soft cloth with a little neutral detergent to clean the outer casing of unit.
(28) If anything abnormal happens (such as burning smell), please power off the unit and cut off the main power supply, and then immediately contact Gree appointed service center .If abnormality keeps going, the unit might be damaged and lead to electric shock or fire.

Any personal injury or property loss caused by improper installation, improper debug, and unnecessary repair or not following the instructions of this manual should not be the responsibility of Gree Electric Appliances, Inc. of Zhuhai.

## 2 Product Introduction

### 2.1 Names of Key Components

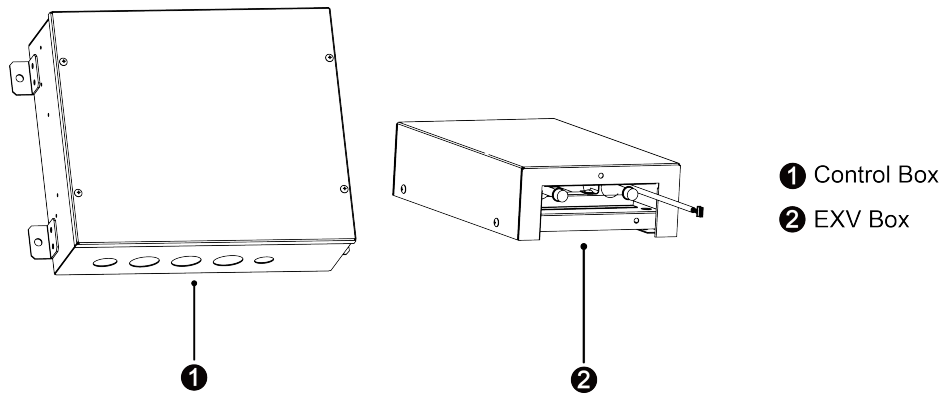

Fig.2.1

### 2.2 Overall System Connection Diagram

When one AHU-KIT is connected to one AHU, the connection diagram is as follows:

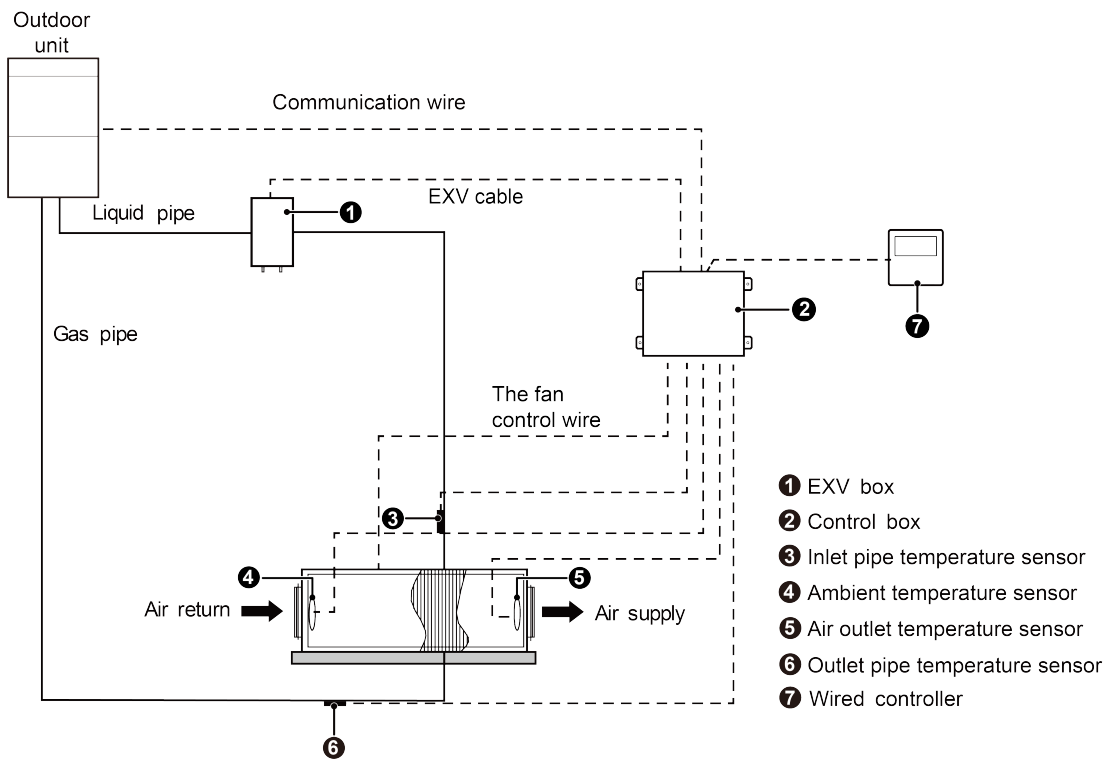

Fig.2.2.1

When several AHU-KITs are in parallel connection with one AHU, the connection diagram is as follows:

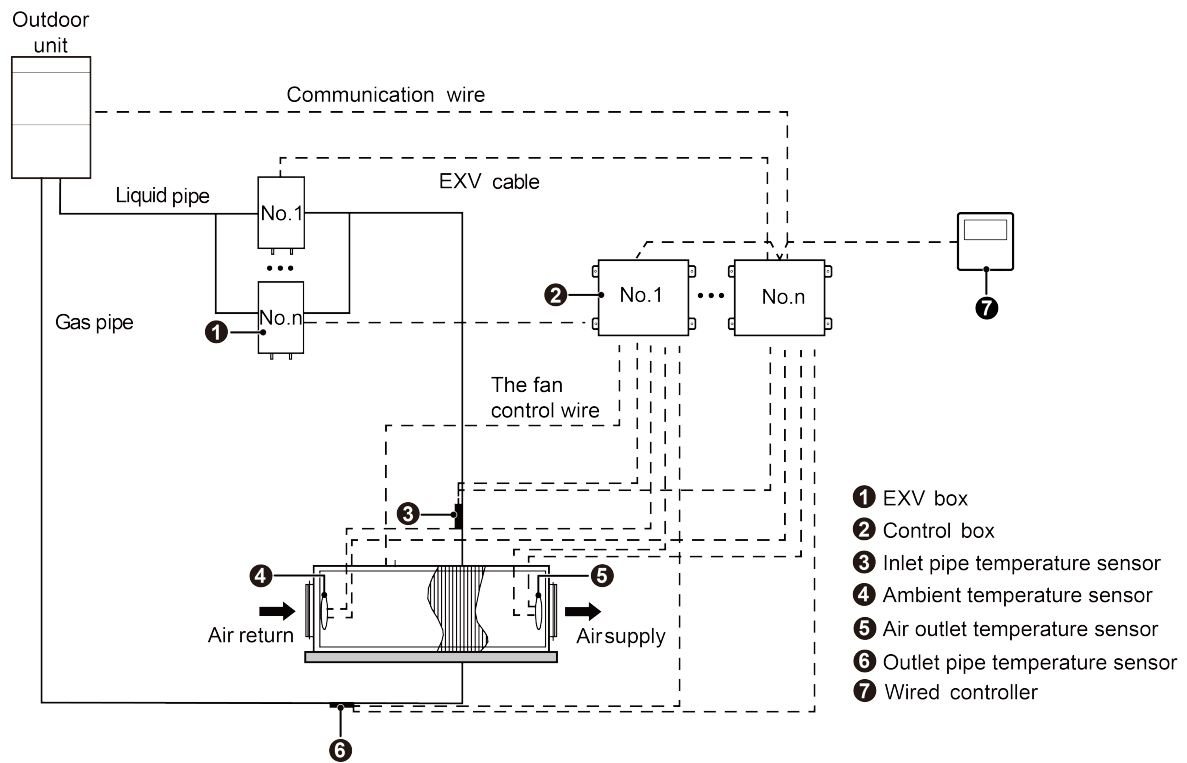









Fig.2.2.2

## 2.3 Standard Fittings

Please use the supplied standard fittings listed below as instructed.

No.	Name	Appearance	Quantity
1	Magnetic ring		1or2
2	Swell screw		4
3	Self-tapping screw		4
4	Bundle		1
5	Operating Instruction Manual		1
6	Wired controller		1
7	Insulator		2
8	Aluminum tape	—	2
9	Rubber belt	—	2

## AHU-KIT

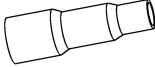
No.	Name	Appearance	Quantity
10	Fastener		4
11	Reducer pipe (Only for 24, 96, 192 type)		2

## 2.4 Specifications

Model		GMV-N12U/C-T(U)		GMV-N24U/C-T(U)			GMV-N48U/C-T(U)					
Defaulted capacity of ex-factory	Capacity		12		24			48				
	Cooling	kW	3.5		7.0			14.1				
		kBtu/h	12.0		24.0			48.0				
	Heating	kW	4.0		7.9			15.8				
		kBtu/h	13.5		27.0			54.0				
Adjustable capacity	Capacity		9	12	15	18	24	30	36	48	60	
	Cooling	kW	2.6	3.5	4.4	5.3	7.0	8.8	10.6	14.1	17.6	
		kBtu/h	9.5	12.0	15.0	18.0	24.0	30.0	36.0	48.0	60.0	
	Heating	kW	3.1	4.0	5.0	5.9	7.9	10.0	11.7	15.8	19.7	
		kBtu/h	10.5	13.5	17.0	20.0	27.0	34.0	40.0	54.0	67.0	
Power input		W	8.0		8.0			8.0				
Power Supply		—	208/230V ~60Hz		208/230V ~60Hz			208/230V ~60Hz				
Size of connection pipe	AHU-KIT (ex-factory pipe size)	mm	Φ6.35	Φ6.35	Φ9.52	Φ9.52	Φ9.52	Φ9.52	Φ9.52	Φ9.52	Φ9.52	
		inch	1/4	1/4	3/8	3/8	3/8	3/8	3/8	3/8	3/8	
	Air handling unit	Liquid pipe	mm	Φ6.35	Φ6.35	Φ6.35	Φ9.52	Φ9.52	Φ9.52	Φ9.52	Φ9.52	Φ9.52
			inch	1/4	1/4	1/4	3/8	3/8	3/8	3/8	3/8	3/8
		Gas pipe	mm	Φ9.52	Φ12.7	Φ12.7	Φ15.9	Φ15.9	Φ15.9	Φ15.9	Φ15.9	Φ19.05
			inch	3/8	1/2	1/2	5/8	5/8	5/8	5/8	5/8	3/4
Connection method		Brazing Connection			Brazing Connection			Brazing Connection				
Outline dimension (W×D×H)	EXV box	mm	203×326×85		203×326×85			203×326×85				
		inch	8×12-7/8×3-3/8		8×12-7/8×3-3/8			8×12-7/8×3-3/8				
	Control box	mm	334×284×111		334×284×111			334×284×111				
		inch	13-1/8×11-1/8×4-3/8		13-1/8×11-1/8×4-3/8			13-1/8×11-1/8×4-3/8				
Net weight	kg	10.0		10.5			10.5					
	LBS	22		23			23					

Model		GMV-N96U/C-T(U)				GMV-N192U/C-T(U)				
Defaulted capacity of ex-factory	Capacity		96				192			
	Cooling	kW	28.1				56.3			
		kBtu/h	96.0				192.0			
	Heating	kW	31.7				63.3			
		kBtu/h	108.0				216.0			
Adjustable capacity	Capacity		72	96	120	144	168	192	288	
	Cooling	kW	21.1	28.1	35.2	42.2	49.2	56.3	84.4	
		kBtu/h	72	96	120	144	168	192	288	
	Heating	kW	23.7	31.7	39.6	47.5	55.4	63.3	95.0	
		kBtu/h	81	108	135	162	189	216	324	
Power input		W	8.0				8.0			
Power Supply		—	208/230V ~60Hz				208/230V ~60Hz			
Size of connection pipe	AHU-KIT (ex-factory pipe size)	mm	Φ9.52	Φ9.52	Φ9.52	Φ9.52	Φ15.9	Φ15.9	Φ15.9	
		inch	3/8	3/8	3/8	3/8	5/8	5/8	5/8	
	Air handling unit	Liquid pipe	mm	Φ9.52	Φ9.52	Φ12.7	Φ12.7	Φ15.9	Φ15.9	Φ19.05
			inch	3/8	3/8	1/2	1/2	5/8	5/8	3/4
		Gas pipe	mm	Φ19.05	Φ22.2	Φ28.6	Φ28.6	Φ28.6	Φ28.6	Φ34.9
			inch	3/4	7/8	1-1/8	1-1/8	1-1/8	1-1/8	1-3/8
Connection method		Brazing Connection				Brazing Connection				



Model			GMV-N96U/C-T(U)	GMV-N192U/C-T(U)
Outline dimension (W×D×H)	EXV box	mm	203×326×85	246×500×120
		inch	8×12-7/8×3-3/8	9-5/8×19-5/8×4-3/4
	Control box	mm	334×284×111	334×284×111
		inch	13-1/8×11-1/8×4-3/8	13-1/8×11-1/8×4-3/8
Net weight	kg		10.5	13.0
	LBS		23	29

Model(Combined)			GMV-N48U/C-T(U) +GMV-N192U/C-T(U)	GMV-N96U/C-T(U) +GMV-N192U/C-T(U)	GMV-N192U/C-T(U) +GMV-N192U/C-T(U)		
Capacity			48+288	96+288	192+288	288+288	
Cooling	kW		98.5	112.5	140.7	168.8	
Cooling	kBtu/h		336	384	480	576	
Heating	kW		110.8	126.6	158.3	189.9	
Heating	kBtu/h		378	432	540	648	
Power input		W	8.0+8.0	8.0+8.0	8.0+8.0		
Power supply		—	208/230V ~60Hz	208/230V ~60Hz	208/230V ~60Hz		
Size of connec tion pipe	Air handli ng unit	Liquid pipe	mm	Φ19.05	Φ19.05	Φ19.05	Φ19.05
			inch	3/4	3/4	3/4	3/4
	Gas pipe	mm	Φ34.9	Φ41.3	Φ41.3	Φ41.3	
		inch	1-3/8	1-5/8	1-5/8	1-5/8	
Outline dimens ion (W×D× H)	Electronic expansion valve box	mm	(203×326×85) +(246×500×120)	(203×326×85) +(246×500×120)	(246×500×120)×2		
		inch	(8×12-7/8×3-3/8) +(9-5/8×19-5/8×4-3/4)	(8×12-7/8×3-3/8) +(9-5/8×19-5/8×4-3/4)	(9-5/8×19-5/8×4-3/4)×2		
	Control box	mm	(334×284×111)×2	(334×284×111)×2	(334×284×111)×2		
		inch	(13-1/8×11-1/8×4-3/8) ×2	(13-1/8×11-1/8×4-3/8) ×2	(13-1/8×11-1/8×4-3/8) ×2		
Net weight		kg	10.5+13.0	10.5+13.0	13.0+13.0		
		LBS	23+29	23+29	29+29		

**NOTICE**

The specifications of the unit is subject to change without prior notice due to improvement product. Please refer to the nameplate.

## 2.5 Recommended Selection of Air Handling Unit

Select the air handling unit according to the technical data and limitations mentioned in the following table. Lifetime of the unit, operation range or operation reliability may be influenced if you neglect these limitations.

Model(Combined)	Capacity (kBtu/h)	Allowed Heat Exchanger Capacity(kBtu/h)			
		Cooling		Heating	
		Min.	Max.	Min.	Max.
GMV-N12U/C-T(U)	9	8.5	9.5	9.5	10.5
	12	9.5	12	10.5	13.5
GMV-N24U/C-T(U)	15	12	15	13.5	17
	18	15	18	17	20
	24	18	24	20	27
GMV-N48U/C-T(U)	30	24	30	27	34
	36	30	36	34	40
	48	36	48	40	54
	60	48	60	54	67
GMV-N96U/C-T(U)	72	60	72	67	81
	96	72	96	81	108
	120	96	120	108	135
	144	120	144	135	162
GMV-N192U/C-T(U)	168	144	168	162	189
	192	168	192	189	216
	288	192	288	216	324
GMV-N48U/C-T(U)+GMV-N192U/C-T(U)	336	288	336	324	378
GMV-N96U/C-T(U)+GMV-N192U/C-T(U)	384	336	384	378	432
GMV-N192U/C-T(U)+GMV-N192U/C-T(U)	480	384	480	432	540
	576	480	576	540	648

### NOTICE

The capacity is obtained at these test conditions: superheat (SH) = 5°C(41°F) and supercool (SC) = 3°C(37.4°F).

Cooling: Saturated evaporating temperature = 6°C(42.8°F), air return temperature is 27°C(80.6°F)DB/19°C(66.2°F)WB.

Heating: Saturated condensing temperature = 46°C(114.8°F), air return temperature is 20°C(68°F)DB.

The heat exchanger of air handling unit is designed for R410A, and its working pressure is 3.8MPa.

Recommendation: Quantity of rows of heat exchanger: no more than 4 rows.

Recommendation: The diameter of copper pipe of heat exchanger is no more than 12.7mm(1/2 inch), 9.52mm(3/8 inch) is recommended.

Air inlet temperature range of heat exchanger: cooling: 16~35°C(60.8~95°F), heating: 10~27°C(50~80.6°F).

### NOTICE

When the AHU-KIT is matched with AHU, they can connect with VRF outdoor unit as VRF

indoor unit. The connection is limited by the outdoor unit. There are three kinds of connection method:

(1) Connection method 1: one-to-one

The AHU-KIT as below can adopt one-to-one connection method with VRF outdoor unit. Total capacity of AHU-KIT should be 50%~110% of that of outdoor unit.

Model(Combined)	Capacity in application (kBtu/h)
GMV-N24U/C-T(U)	24
GMV-N48U/C-T(U)	30
	36
	48
	60
GMV-N96U/C-T(U)	72
	96
	120
	144
GMV-N192U/C-T(U)	168
	192
	288
	336
GMV-N48U/C-T(U)+GMV-N192U/C-T(U)	336
GMV-N96U/C-T(U)+GMV-N192U/C-T(U)	384
GMV-N192U/C-T(U)+GMV-N192U/C-T(U)	480
	576

(2) Connection method 2: one-to-more

The AHU-KIT as below can adopt one-to-more connection method with VRF outdoor unit.

Total capacity of AHU-KIT should be 50%~110% of that of outdoor unit.

Model	Capacity in application (kBtu/h)
GMV-N12U/C-T(U)	9
	12
GMV-N24U/C-T(U)	15
	18
	24
GMV-N48U/C-T(U)	30
	36
	48
	60
GMV-N96U/C-T(U)	72
	96
	120
	144
GMV-N192U/C-T(U)	168
	192
	288

**NOTICE**

9~144 kBtu/h units can be connected to the same system; 72~288 kBtu/h units can be connected to the same system.

(3) Connection method 3: one-to-more (mixed connection)

The AHU-KIT as below can adopt one-to-more connection method with general VRF indoor unit. Total capacity of AHU-KIT and VRF indoor unit should be 50%~110% of that of outdoor unit. Total capacity of AHU-KIT cannot exceed 30% of that of outdoor unit.

Model	Capacity in application (kBtu/h)
GMV-N12U/C-T(U)	9
	12
GMV-N24U/C-T(U)	15
	18
	24
GMV-N48U/C-T(U)	30
	36
	48
	60
GMV-N96U/C-T(U)	72
	96

**NOTICE**

When connecting AHU-KIT with general VRF indoor unit, capacity requirement shall be followed strictly. Otherwise, it may affect the operation, or even damage the unit.

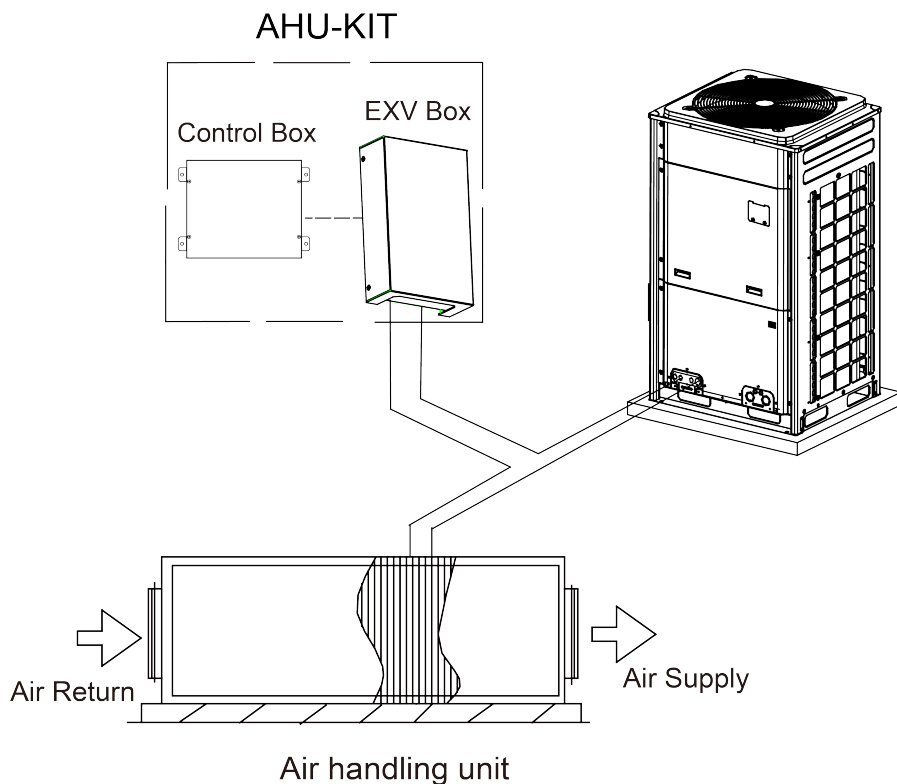

Fig.2.5.1 AHU-KIT one-to-one (single unit) connection diagram

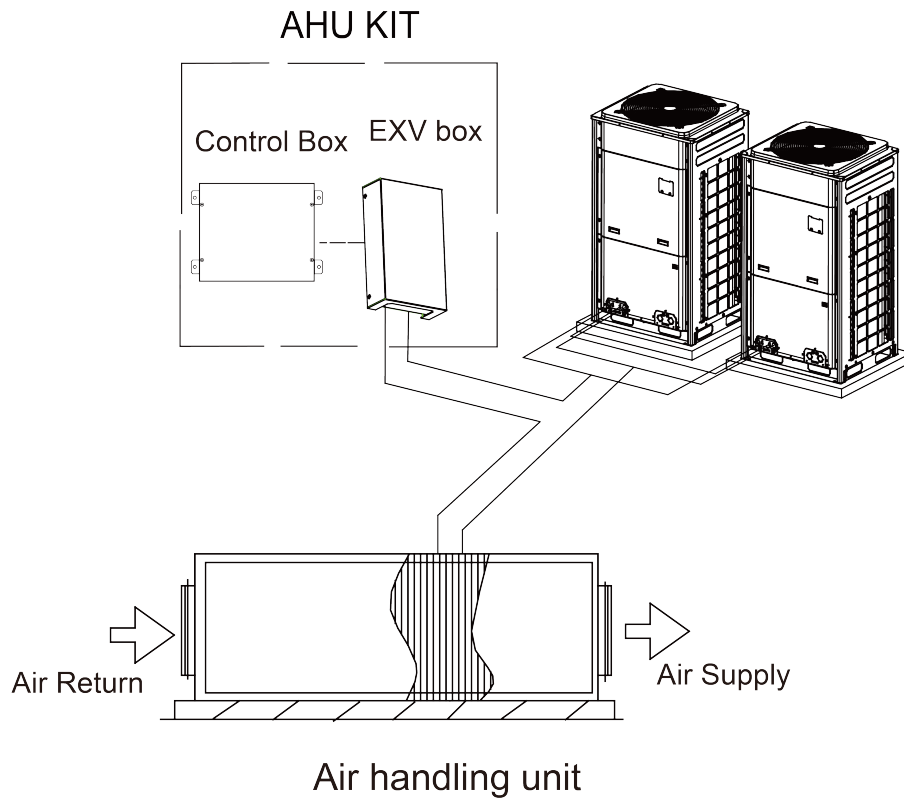

Fig.2.5.2 AHU-KIT one-to-one (combination outdoor unit) connection diagram

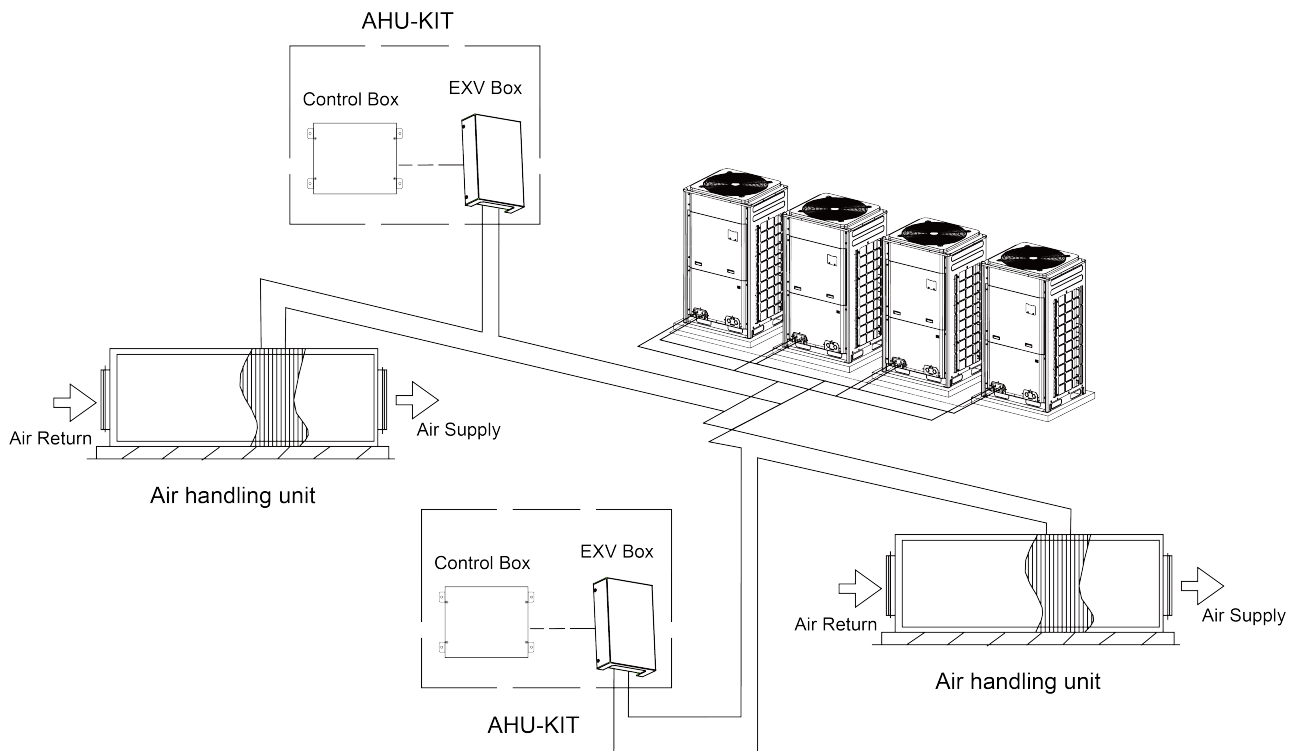

Fig.2.5.3 AHU-KIT one-to-more connection diagram

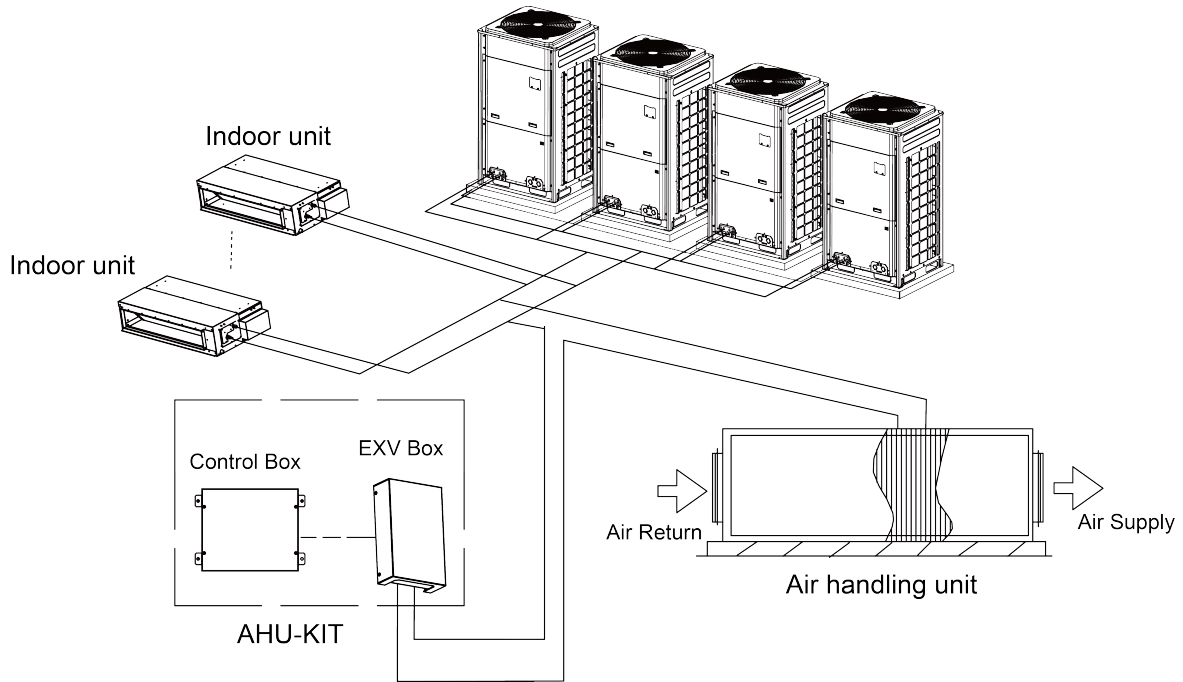

Fig.2.5.4 AHU-KIT one-to-more (hybrid connection) connection diagram

### 3 Preparations for Installation

#### 3.1 Before Installation

**NOTICE**

Product graphics are only for reference. Please refer to actual products. Unspecified measure unit is mm(inch).

- (1) This equipment is designed for R410A system, and the designed working pressure is 4.3MPa or 43bar.
- (2) Working Ambient Temp. Tmax=113°F (45°C).
- (3) Precautions for R410A:
  - a).The refrigerant requires strict cautions for keeping the system clean, dry and tight.
    - Clean and dry: Foreign materials (including mineral oils or moisture) should be prevented from getting mixed into the system.
    - Tight: Read this manual carefully and follow these procedures correctly.
  - b).Since R410A is a mixed refrigerant, the required additional refrigerant must be charged in its liquid state. (If the refrigerant is in state of gas, its composition changes and the system will not work properly).
- (4) The connected air handling units must have heat exchangers designed exclusively for R410A.

(5) Never use this appliance in a place with inflammable and explosive gas.

(6) For the following items, take special care during construction and check after installation is finished:

Tick <input checked="" type="checkbox"/> when checked
<input type="checkbox"/> Are the temperature sensors fixed firmly? Temperature sensor may come loose.
<input type="checkbox"/> Is the capacity code set correctly? System performance may not reach relevant requirements or will lead to reliability problem.
<input type="checkbox"/> Is the control box fixed firmly? The unit may drop, vibrate or make noise.
<input type="checkbox"/> Do electrical connections comply with specifications? The unit may malfunction or components may burn out.
<input type="checkbox"/> Are wiring and piping correct? The unit may malfunction or components may burn out.
<input type="checkbox"/> Is the unit safely grounded? Dangerous at electric leakage.

### 3.2 Location for Installation

Select an installation site where the following conditions are fulfilled and that meets your customer's approval.

- (1) The EXV box can be installed inside and outside. The control box should be installed inside.
- (2) Do not install the EXV box in or on the outdoor unit.
- (3) Do not put the option boxes in direct sunlight. Direct sunlight will increase the temperature inside the option boxes and may reduce its lifetime and influence its operation.
- (4) Choose a flat and strong mounting surface.
- (5) Make sure there is enough free space in front and in the side of the AHU-KIT unit for future maintenance.
- (6) The installation site should be far away from heat source, inflammable gas and smoke.
- (7) Keep the air handling unit, power supply wiring and transmission wiring at least 1m(39-3/8 inch) away from televisions and radios. This is to prevent image interference and noise in those electrical appliances (Noise may be generated depending on the conditions under which the electric wave is generated, even if 1m(39-3/8 inch) is kept.).
- (8) Make sure the electronic expansion valve is installed in an upright position.

**NOTICE**

Do not install or operate the unit in rooms mentioned below:

- a) Where mineral oil, like cutting oil is present.
- b) Where the air contains high levels of salt such as air near the ocean.
- c) Where sulphurous gas is present such as that in areas of hot spring.
- d) In vehicles or vessels.
- e) Where voltage fluctuates a lot such as that in factories.
- f) Where high concentration of vapor or spray are present.
- g) Where machines generating electromagnetic waves are present.
- h) Where acidic or alkaline vapor is present.

Installing this unit must comply with the relevant local and national codes.

Connecting the power after all installation works are done.

### 3.3 Requirements for Communication Wire

#### **NOTICE**

If the unit is installed in the place with strong electromagnetic interference, shielded wire must be applied on the communication wire between indoor unit (AHU-KIT) and wired controller. Twisted pair wire with shielding function must be applied on the communication wire between indoor unit and indoor unit (outdoor unit).

#### 3.3.1 Selecting communication wire for AHU-KIT and wired controller

Wire type	Total length of communication wire between indoor unit and wired controller	Wire size	Remarks
Light/Ordinary polyvinyl chloride sheathed cord.	$L \leq 250\text{m}$ ( $L \leq 820\text{-}1/4\text{feet}$ )	$2 \times \text{AWG}18 \sim 2 \times \text{AWG}16$	<ol style="list-style-type: none"> <li>1. Total length of communication cable can't exceed 250m (820-1/4feet).</li> <li>2. The cord shall be Circular cord (the cores shall be twisted together).</li> <li>3. If unit is installed in places with intense magnetic field or strong interference, it is necessary to use shielded wire.</li> </ol>

Connection between AHU-KIT and wired controller is shown as follows:

- (1) When one AHU-KIT is connected to one AHU, you can adopt the connection ways of one wired controller to one AHU-KIT or one wired controller to several AHU-KITs (group control,  $n \leq 16$ ).
- (2) When several AHU-KITs are in parallel connection with one AHU, you can only adopt the way of one wired controller to several AHU-KITs (group control).



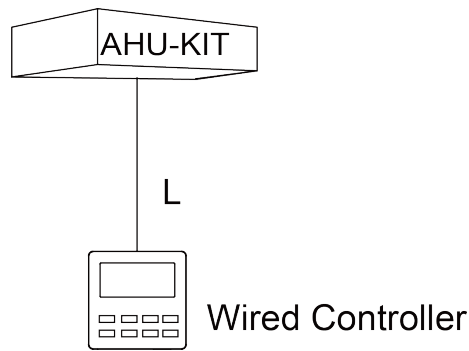

Fig.3.3.1 one wired controller to one AHU-KIT

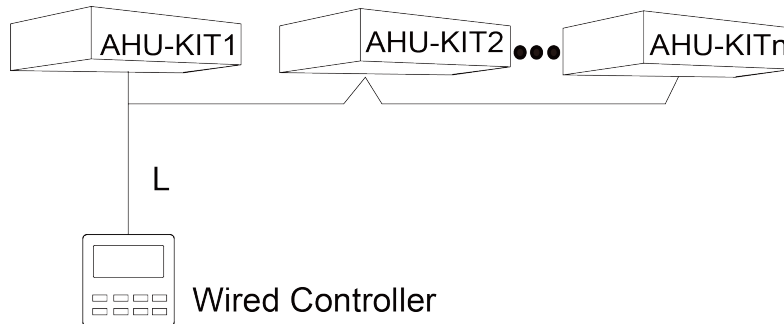

Fig.3.3.2 one wired controller to several AHU-KITs

3.3.2 Select Communication wire for AHU-KIT and Outdoor Unit

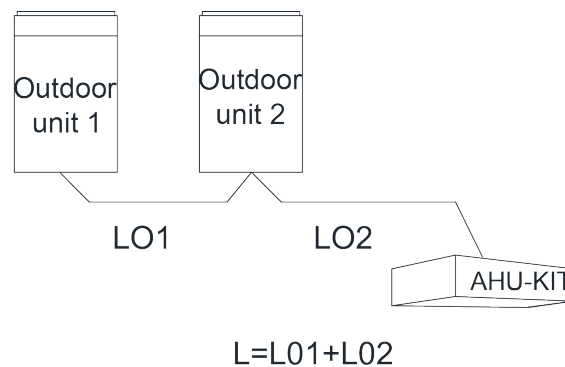

Fig.3.3.3

Wire type	Total Length L of Communication Cable between Indoor Unit and Indoor (Outdoor) Unit	Wire size	Remarks
Light/Ordinary polyvinyl chloride sheathed cord.	$L \leq 1000m$ ( $L \leq 3280-7/8$ feet)	$\geq 2 \times AWG18$	1. If the wire diameter is enlarged to $2 \times AWG16$ , the total communication cable length can reach 1500m (4921-1/4feet). 2. The cord shall be Circular cord (the cores shall be twisted together). 3. If unit is installed in places with intense magnetic field or strong interference, it is necessary to use shielded wire.

### 3.4 Wiring Requirements

Power Cord Size and Air Switch Capacity:

Model	Power Supply	Fuse Capacity(A)	Minimum Circuit Capacity(A)	Maximum Overcurrent Protection(A)
GMV-N12U/C-T(U)	208/230V ~60Hz	15	10	15
GMV-N24U/C-T(U)		15	10	15
GMV-N48U/C-T(U)		15	10	15
GMV-N96U/C-T(U)		15	10	15
GMV-N192U/C-T(U)		15	10	15

#### NOTICE

Use copper wire only as unit's power cord. Operating temperature should be within its rated value.

- ① Above selection requirements: Power cord size is based on BV single-core wire (2~4pc) at 40°C(104°F) ambient temperature when laying across plastic pipe. Air switch is D type and used at 40°C(104°F). If actual installation condition varies, please lower the capacity appropriately according to the specifications of power cord and air switch provided by manufacturer.
- ② Install cut-off device near the unit. The minimum distance between each stage of cut-off device should be 3 mm(1/8 inch) (The same for both indoor unit and outdoor unit).

### 3.5 Piping Requirements

#### 3.5.1 Selection of Piping Requirements

- (1) Ensure the inside of the pipes is clean and no foreign materials.
- (2) Pipe specifications:

R410A System		
Pipe Diameter mm(inch)	Wall Thickness mm(inch)	Temper grade of piping material
Φ6.35(1/4)	≥0.8(1/32)	O
Φ9.52(3/8)	≥0.8(1/32)	O
Φ12.70(1/2)	≥0.8(1/32)	O
Φ15.9(5/8)	≥1.0(3/76)	O
Φ19.05(3/4)	≥1.0(3/76)	1/2H
Φ22.2(7/8)	≥1.2(1/21)	1/2H
Φ28.6(1-1/8)	≥1.2(1/21)	1/2H
Φ34.90(1-3/8)	≥1.3(2/39)	1/2H
Φ41.30(1-5/8)	≥1.5(1/17)	1/2H

### 3.5.2 Piping Design

When one AHU-KIT is connected to one AHU, the piping diagram is as follows:

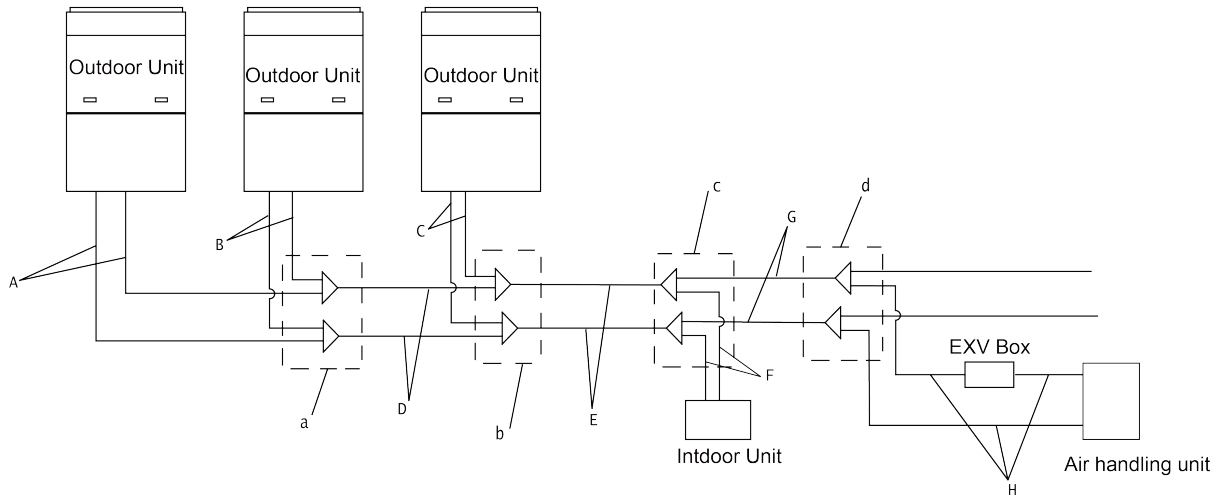

Fig.3.5.1 One AHU-KIT to one AHU

When several AHU-KITs are connected to one AHU, the piping diagram is as follows:

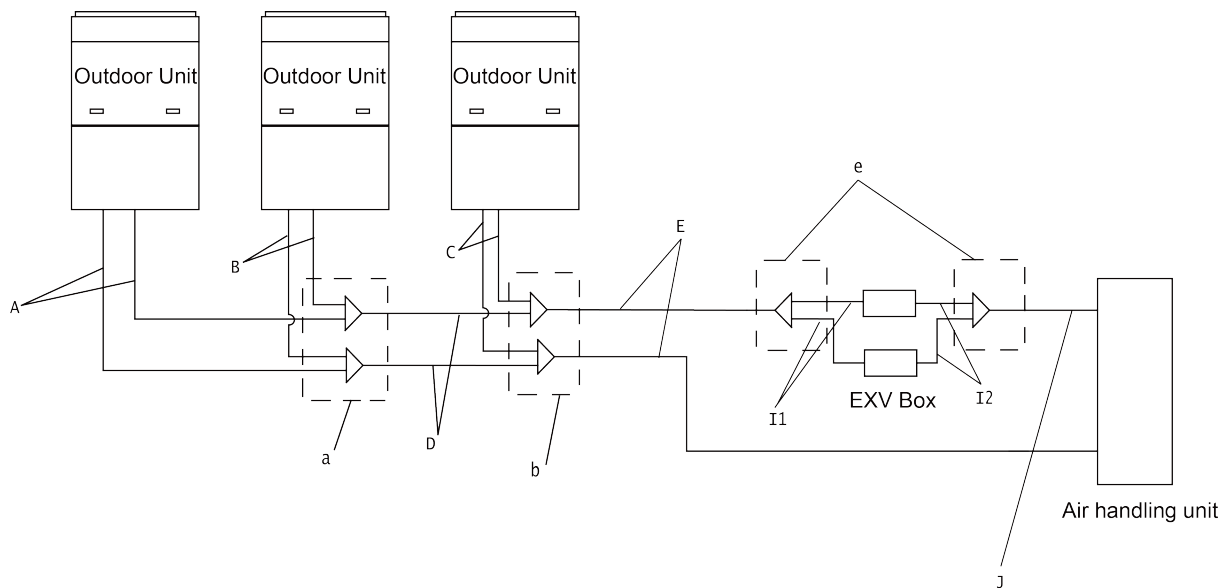

Fig.3.5.2 Several AHU-KITs to one AHU

#### 3.5.2.1 Selection of Branch Pipe

(1) Branch pipes (a, b) between outdoor units shall be selected according to the total capacity of outdoor unit ,as follows:

—	Model
Selection of branch pipe between ODU modules	ML01/A

(2) Branch pipe (c, d) between indoor units shall be selected according to the total capacity of downstream IDUs, as follows:

Selection of branch pipe between indoor units	Total rated capacity of downstream IDUs C(kBtu/h)	Model
Y-type Manifold	$C < 68$	FQ01A/A
	$68 \leq C \leq 102$	FQ01B/A
	$102 < C \leq 239$	FQ02/A
	$239 < C \leq 461$	FQ03/A
	$461 < C$	FQ04/A
T-type Manifold	$C \leq 136$	FQ14/H1
	$C \leq 232$	FQ18/H1
	$232 < C$	FQ18/H2

(3) When several AHU-KITs are connected to one AHU, branch pipe (e) shall be selected according to the following table:

Model(Combined)	Branch pipe	Quantity
GMV-N48U/C-T(U)+GMV-N192U/C-T(U)	FQ02U/A	1
GMV-N96U/C-T(U)+GMV-N192U/C-T(U)	FQ02U/A	1
GMV-N192U/C-T(U)+GMV-N192U/C-T(U)	FQ02U/A	1

### 3.5.2.2 Selection of Piping Dimension

Piping dimension can be selected according to the total rated capacity of upstream or downstream modules. Detailed requirements are as below:

- (1) Piping (A, B, C) from ODU to branch pipe shall be selected according to the rated capacity of ODU;
- (2) Piping D between branch pipes of ODU modules shall be selected according to the total rated capacity of upstream modules;
- (3) Piping E and G of branch pipe at IDU side shall be selected according to the total rated capacity of downstream IDUs;
- (4) Piping F from IDU branch pipe to IDU shall be selected according to the rated capacity of IDU;
- (5) Piping (I1, I2, J, H) between branch pipe and AHU-KIT shall be selected according to the capacity of AHU-KIT.

Relationship between capacity and piping dimension is as below:

Rated capacity (kBtu/h)	Gas pipe mm(inch)	Liquid pipe mm(inch)
$Q \leq 72$	$\Phi 19.05(3/4)$	$\Phi 9.52(3/8)$
$72 < Q \leq 96$	$\Phi 22.2(7/8)$	$\Phi 9.52(3/8)$
$96 < Q \leq 120$	$\Phi 28.6(1-1/8)$	$\Phi 12.7(1/2)$
$120 < Q \leq 144$	$\Phi 28.6(1-1/8)$	$\Phi 12.7(1/2)$
$144 < Q \leq 168$	$\Phi 28.6(1-1/8)$	$\Phi 15.9(5/8)$

Rated capacity (kBtu/h)	Gas pipe mm(inch)	Liquid pipe mm(inch)
168<Q≤216	Φ28.6(1-1/8)	Φ15.9(5/8)
216<Q≤240	Φ34.9(1-3/8)	Φ15.9(5/8)
240<Q≤312	Φ34.9(1-3/8)	Φ19.05(3/4)
312<Q≤336	Φ34.9(1-3/8)	Φ19.05(3/4)
336<Q≤576	Φ41.3(1-5/8)	Φ19.05(3/4)

**NOTICE**

- ① As the capacity of AHU-KIT is adjustable, please select piping according to actual capacity in the project.
- ② If the ex-factory pipe diameter of AHU adapter is inconsistent with the actual required pipe diameter for the project, please conduct conversion or flaring treatment on site.

**3.6 Capacity Setting**

Capacity ranges of different AHU-KIT unit are as follows:

Model	Acquiescent capacity (kBtu/h)	Adjustable capacity(kBtu/h)
GMV-N12U/C-T(U)	12	9/12
GMV-N24U/C-T(U)	24	15/18/24
GMV-N48U/C-T(U)	48	30/36/48/60
GMV-N96U/C-T(U)	96	72/96/120/144
GMV-N192U/C-T(U)	192	168/192/288

Different capacities of same model of AHU-KIT unit are achieved through dialing capacity code of mainboard (shown as "S1").Capacity code setting is shown as follows:

S1					Capacity (kBtu/h)
1	2	3	4	5	
0	1	0	0	0	9
0	0	1	0	0	12
0	1	1	0	0	15
0	0	0	1	0	18
0	1	0	1	0	24
0	0	1	1	0	30
0	1	1	1	0	36
0	0	0	0	1	48
0	1	0	0	1	60
1	1	0	0	1	72
1	0	1	0	1	96
0	1	1	0	1	120
0	0	0	1	1	144
0	1	0	1	1	168
1	1	0	1	1	192
0	0	1	1	1	288

Please ensure dialing the code switch properly in place instead of middle position. Setting the switch to "ON" stands for "0", otherwise stands for "1".

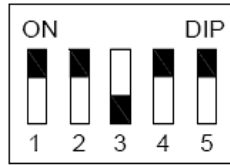

(NOTICE: The black part is the deflector rod.) The figure shows that the addresses of "1,2,3,4,5" are "0,0,1,0,0".

<b>NOTICE</b>
① The selected air handling unit must be designed for R410A.
② Extraneous substances (including mineral oils or moisture) must be prevented from getting mixed into the system.

## 4 Installation Instructions

### 4.1 Unit Dimensions and Maintenance Space

(1) Size of control box for GMV-N12U/C-T(U)、GMV-N24U/C-T(U)、GMV-N48U/C-T(U)、GMV-N96U/C-T(U) and GMV-N192U/C-T(U) :

Unit: mm(inch)

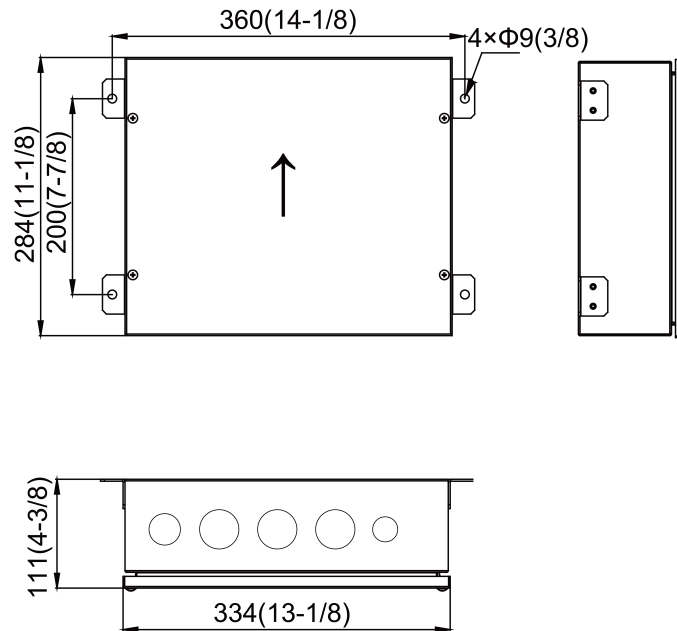

Fig.4.1.1

(2) Size of EXV box for GMV-N12U/C-T(U):

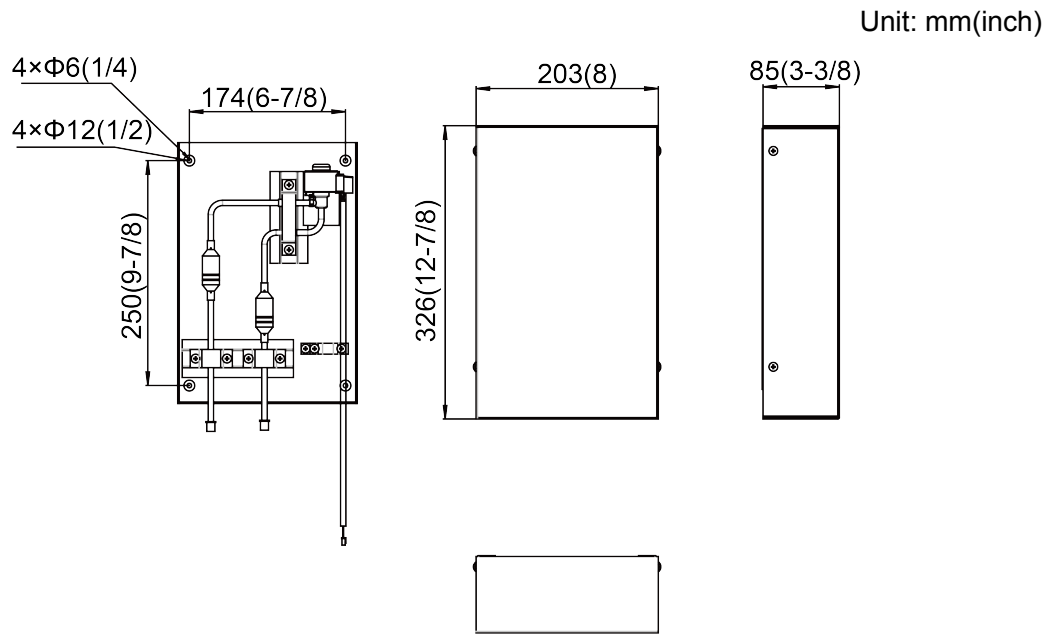

Fig.4.1.2

(3) Size of EXV box for GMV-N24U/C-T(U), GMV-N48U/C-T(U), GMV-N96U/C-T(U):

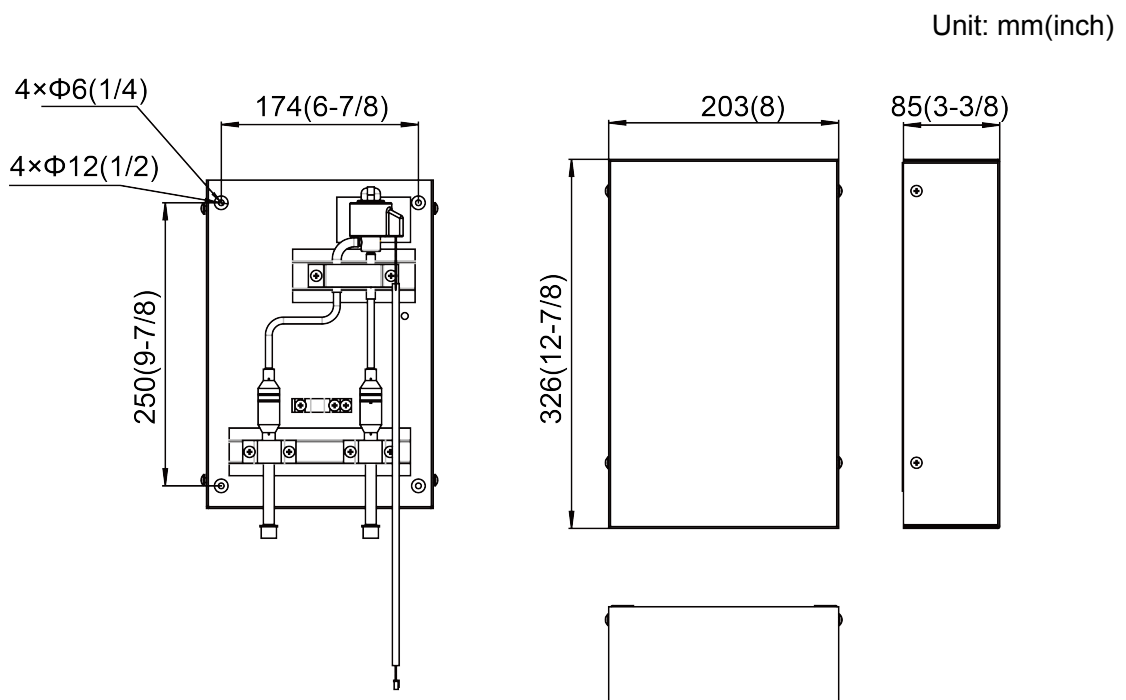

Fig.4.1.3

(4) Size of EXV box for GMV-N192U/C-T(U):

Unit: mm(inch)

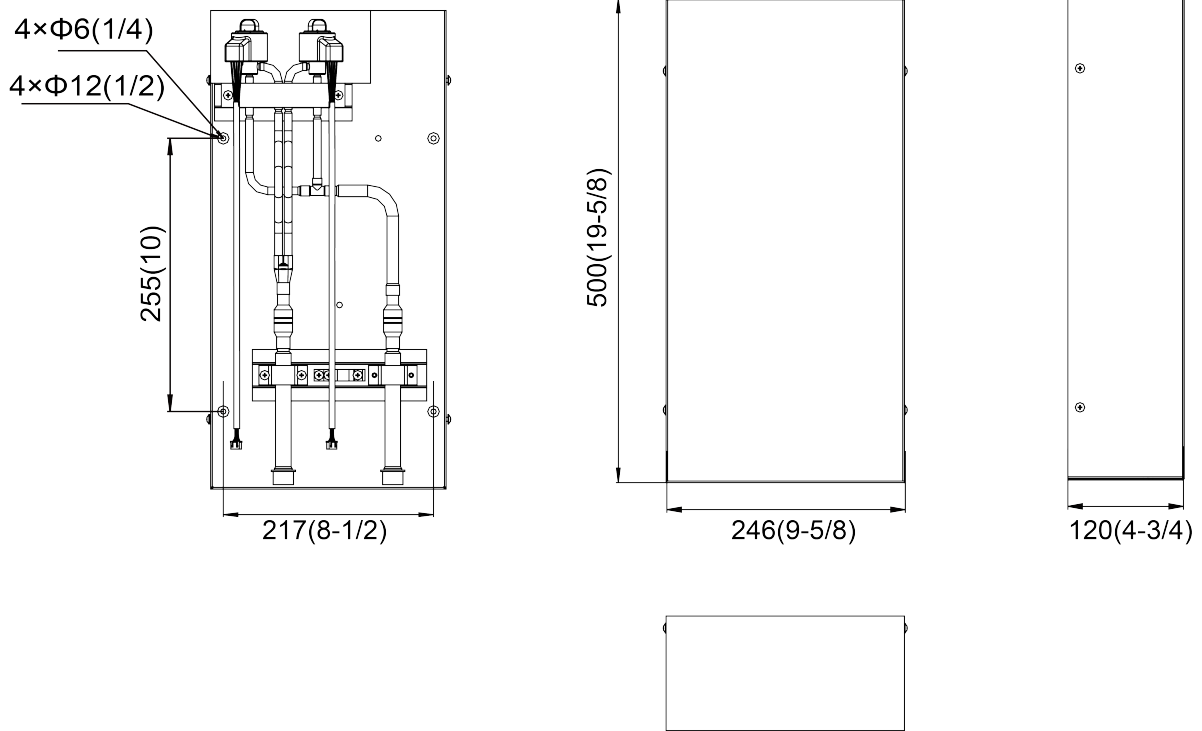
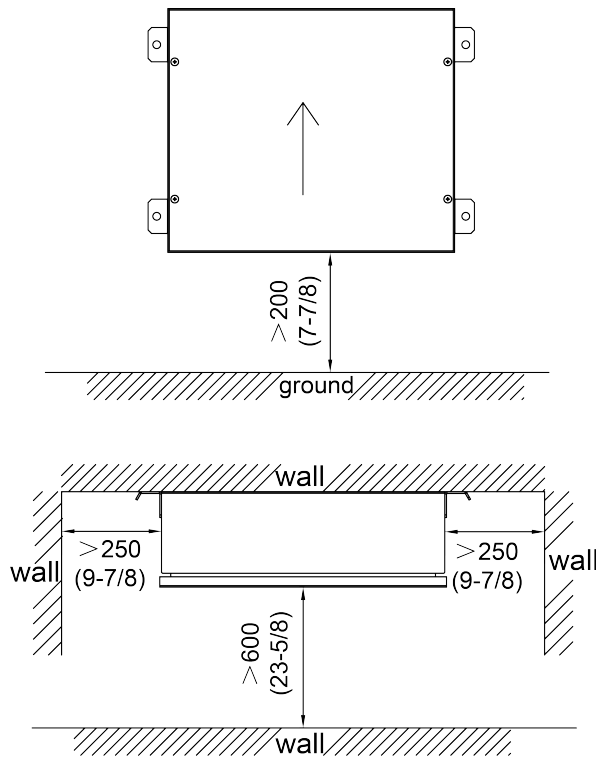

Fig.4.1.4

(5) Maintenance space of control space:

Unit: mm(inch)



The control box must be installed upwards as the direction of the arrow shown in the figure

Fig.4.1.5



## (6) Maintenance space of EXV box:

Unit: mm(inch)

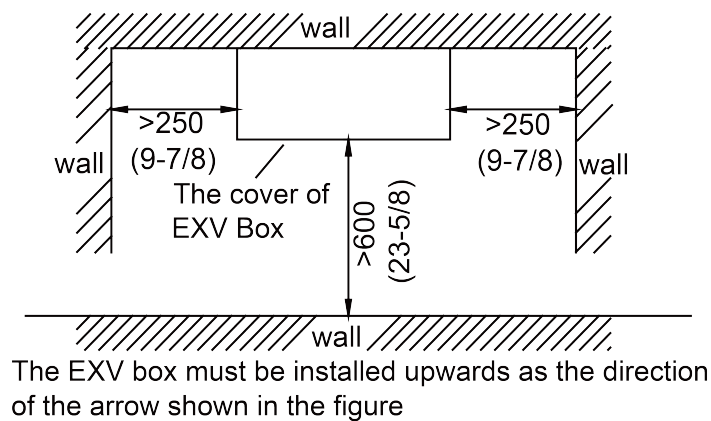
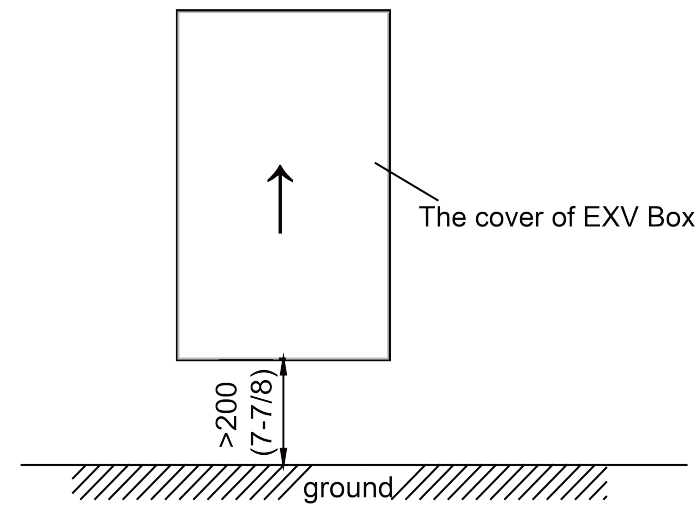

Fig.4.1.6

## 4.2 EXV Installation

### 4.2.1 Mechanical Installation

- (1) Remove the EXV box cover by unscrewing screws.
- (2) Drill 4 holes on correct position (measurements as indicated in figure below) and fix the valve kit box securely with 4 screws through the provided holes  $\phi 12\text{mm}(1/2 \text{ inch})$ .

#### **NOTICE**

- ① Make sure that the EXV box is installed upwards.
- ② Make sure there is enough free space in front and in the side of the box for future maintenance.

## 4.2.2 Brazing Work

(1) Prepare the inlet/outlet field piping just in front of the connection (do not braze yet).

Unit: mm(inch)

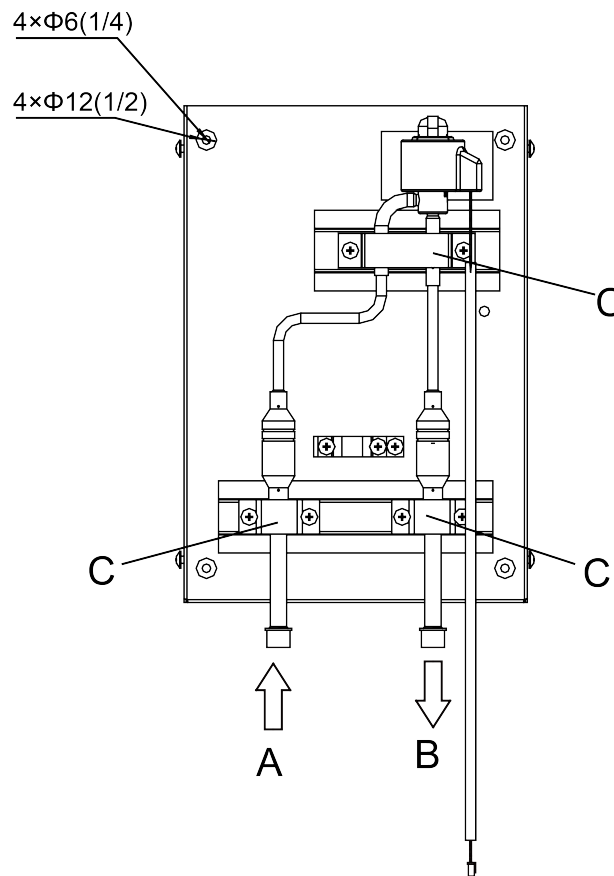

Fig.4.2.1

A: Inlet coming from the outdoor unit

B: Outlet to air handling unit

C: Wire clamp

(2) Remove the wire clamp (C) by unscrewing 6×M4.2.

(3) Braze the field piping.

**NOTICE**

(1) Make sure there is nitrogen protection during welding.

Brazing without carrying out nitrogen replacement or releasing nitrogen into the piping will create large quantities of oxidized film on the inside of the pipes, adversely affecting valves and compressors in the refrigerating system and preventing normal operation.

(2) When brazing while inserting nitrogen into the piping, nitrogen must be set to 0.02MPa with a pressure-reducing valve (=just enough so that it can be felt on the skin).

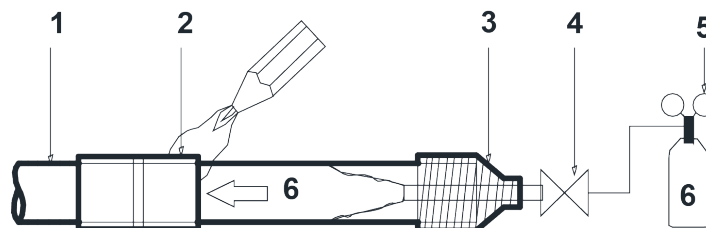
**NOTICE**

- 1) Refrigerant piping
- 2) Part to be brazed
- 3) Taping
- 4) Hands valve
- 5) Pressure-reducing valve
- 6) Nitrogen

For details, see manual of the outdoor unit.

(3) Make sure to cool the filters and valve body with a wet cloth and make sure the body temperature does not exceed 120°C(248°F) during brazing.

(4) Make sure that the other parts such as electrical box, tie wraps and wires are protected from direct brazing flames during brazing.

(5) The EXV box is required to be installed in a vertical direction within the range of  $90\pm 15^\circ$  (not allowed for horizontal work). Welding the connection tubes first before refrigerant pipes in order to avoid face-down soldering.

(6) All field piping must be provided by a licensed refrigeration technician and must comply with the relevant local and national codes.

- a) For refrigerant piping of outdoor unit, refer to the installation manual supplied with the outdoor unit.
- b) The maximum allowed piping length depends on the connected outdoor model.

(4) Secure the wire clamp (C) in place again (6×M4.2).

(5) Make sure that field pipes are fully insulated. Make sure that there is no gap between both ends in order to avoid condensation dripping (finish the connection with tape eventually).

### 4.2.3 Installation handbook of the EXV cable

#### 4.2.3.1 Installation steps

- (1) Making the cable terminal through the Cable-Cross Loop (Fig.4.2.2), and then winding the cable on the magnetic ring for three times(Fig.4.2.3), at last inserting the terminal into a corresponding slot(see circuit diagram).
- (2) Using bundles to fix the magnetic ring is required. It's also need to insert the bundle into the reserved hole on the control box.
- (3) Fixing the cable with the wire clamp, and tightening the Cable-Cross Loop.
- (4) Fix the magnetic ring to the reserved hook fixing inside electrical box with high-temperature bonding tie.
- (5) Screw the joint.

### 4.2.3.2 Installation requirements

- (1) Ensure that the cable in the control box is in a relaxed state, and both the joint of terminal and the fixed place of magnetic ring are all not under a stress.
- (2) Ensure that the cable sheath port is located in the control box in order to prevent the rainch.

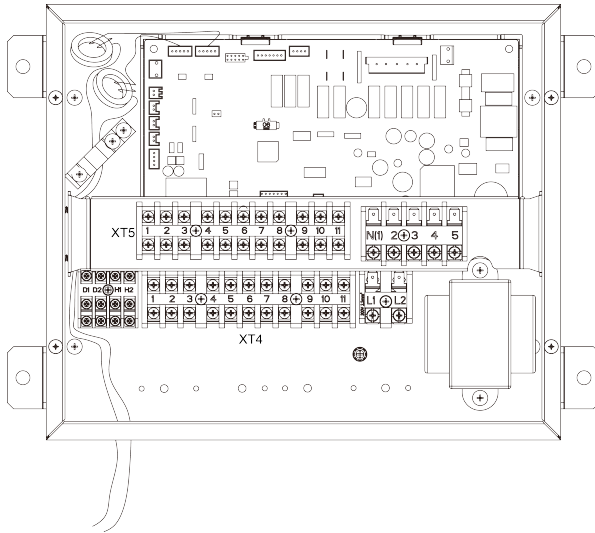

Fig.4.2.2

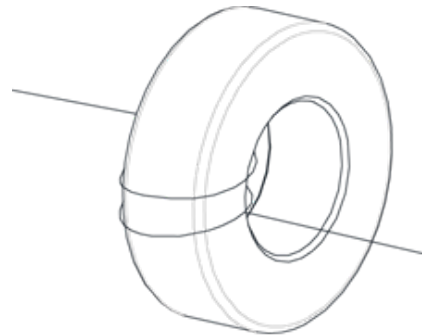

Fig.4.2.3

The quantity of expansion valve coil is determined by the actual number of fittings, The length of EXV Cable wire is 10m(393-3/4 inch) (24,48,96,192 type) or 2.5m(98-3/8 inch) (12 type).

### 4.3 Installation of the EXV Cable

Referring to the circuit diagram, then connect the EXV cable to the circuit-board of control box. Be sure that the cable is fixed firmly in order to ensure a good pull relieve and water protection.

### 4.4 Piping Installation

When one AHU-KIT is connected to one AHU, the piping installation diagram is as follows:

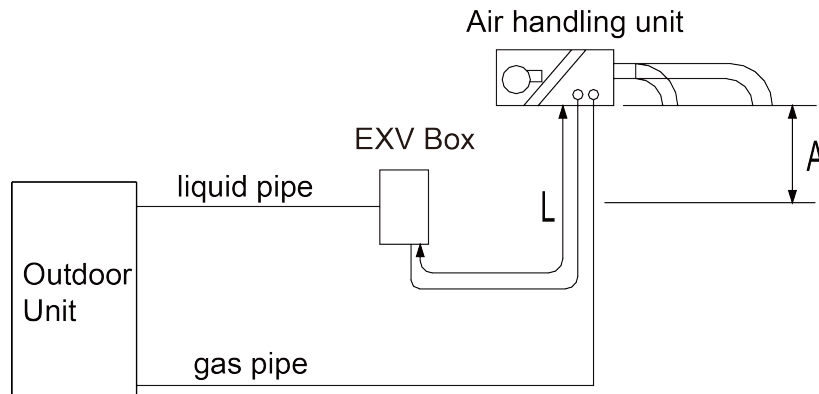

Fig.4.4.1

When several AHU-KITs are connected to one AHU, the piping installation diagram is as

follows:

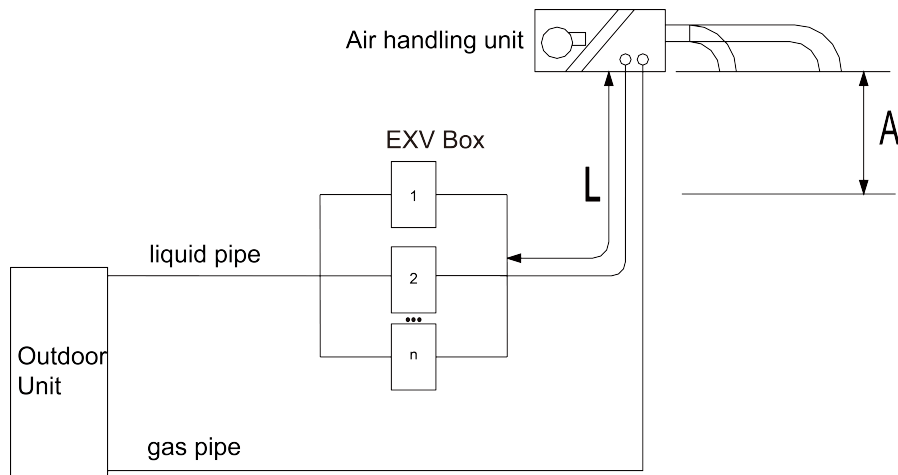

Fig.4.4.2

### **NOTICE**

A: When the air handling unit is installed at the top of the EXV box, vertical distance between the bottom of the air handling unit to the EXV box is no more than 2m(78-3/4 inch); if the air handling unit is installed under the EXV box, vertical distance between the bottom of the air handling unit to the EXV box is no more than 2m(78-3/4 inch).

L: The length of liquid pipe between the air handling unit to EXV box is no more than 2m(78-3/4 inch).

L is to be considered as a part of the total maximum piping length. See installation manual of the outdoor unit for piping installation.

## 4.5 Installation of the Control Box

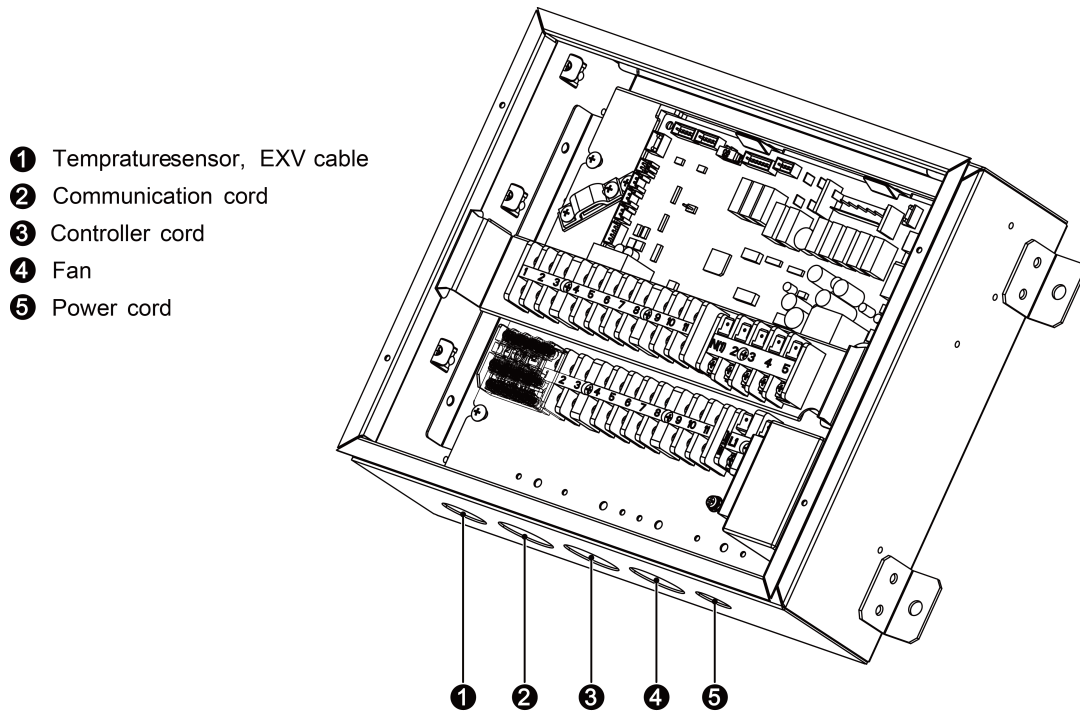

Fig.4.5.1

- (1) Fix the control box with its hanger brackets to the mounting surface.
- (2) Open the lid of the control box.
- (3) For electrical wiring: refer to the following contents.
- (4) Install the screw nuts.
- (5) Close the unnecessary openings.
- (6) Close the lid securely after installation to ensure that the control box is watertight.

### 4.5.1 Wire connection of single AHU-KIT control part

#### **NOTICE**

- ① Pull the wires inside through the screw nut and close the nut firmly in order to ensure a good pull relieve and water protection.
- ② The cables require an additional pull relief. Fixing the cable with the wire clamp.

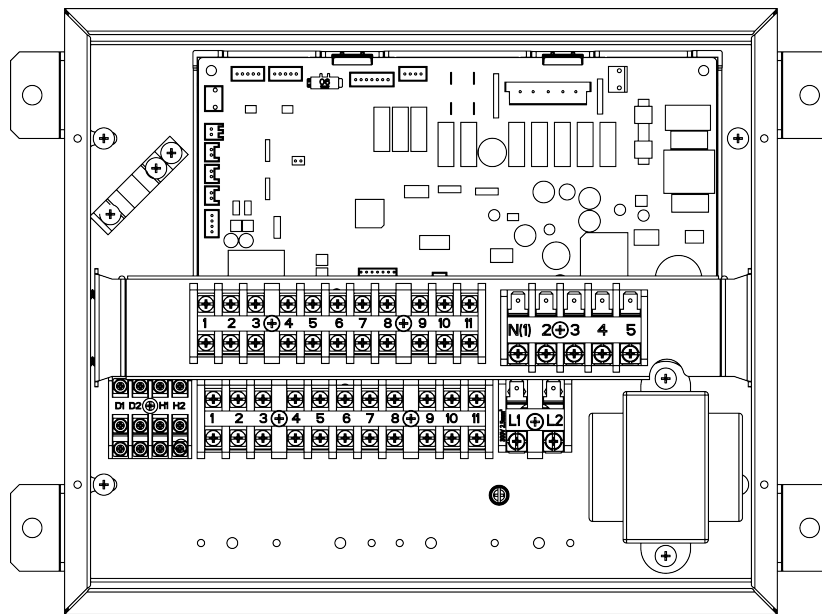

Fig.4.5.2

Precautions:

- ① Temperature sensor cable and remote controller wire should be kept away from power cable in a distance of at least 50mm(2 inch). Violating this rule may generate electric noise and lead to malfunctions.
- ② Use wires as specified and connect them tightly with wiring terminals. Keep the wires in order and do not obstruct other devices. Insecure connection may result in overheating or even cause electric shock or fire hazard.

Wiring connection:

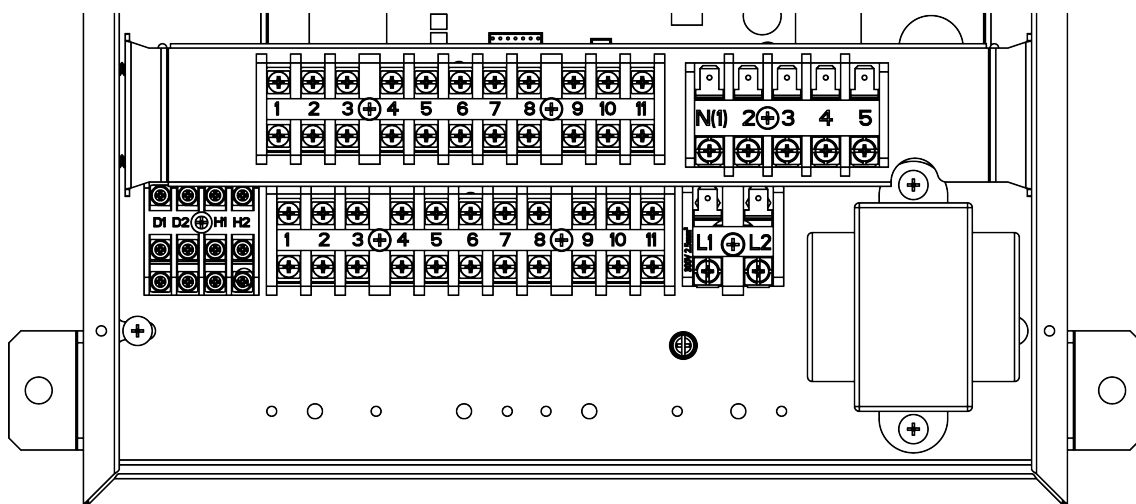



Fig.4.5.3

Connecting cables according to the following instructions, as figure shown above.

L1.....Live

L2.....Neutral

- .....Protective earth (screw)
- 2.....High gear of fan
- 3.....Middle gear of fan
- 4.....Low gear of fan
- D1/D2.....Communication wires
- H1/H2.....Wired controller

<b>NOTICE</b>
① The 2, 3, 4 of fan gear lines are shorted by the factory default.
② Neutral line of fan connects to the N(1).
③ It can be connected to any of them (2, 3, 4) when there is only one gear.
④ Disconnect the short cable between 2 and 3 when there are two gears, then connect the high gear cable to 2, and connect low gear cable to either 3 or 4.
⑤ When there are three gears, disconnect the short cables between 2 and 3, 3 and 4, then connect the high gear cable, middle gear cable and low gear cable to 2,3,4 for each.
⑥ Pull the wires inside through the screw nut and close the nut firmly in order to ensure a good pull relieve and water protection.
⑦ Put through the wires to the coil, tighten the coil while maintaining loose condition of wires to ensure it is not closely tied up and is waterproof.
⑧ Wiring connection of XT4 and XT5 refer to the following contents.

#### 4.5.2 Wire connection of multiple AHU-KIT control parts

When multiple AHU-KITs control an air handling unit, connect fan control wire and external signal feedback signal wire of air handling unit to any one AHU-KIT. Please refer to the wiring method of AHU-KIT for the connection method.

### 4.6 Installation of the Temperature Sensors

#### 4.6.1 Refrigerant Temperature Sensors

Location of the temperature sensor: A correct installation of the temperature sensors is required to ensure a good operation.

(1) Inlet pipe temperature sensor (Liquid Temperature sensor)

Install the IN temperature sensor after the distributor and on the coldest temperature pipe of a heat exchanger.

(2) Outlet pipe temperature sensor (gas Temperature sensor)

Install the OUT temperature sensor 200mm(7-7/8 inch) after the outlet of the heat exchanger.



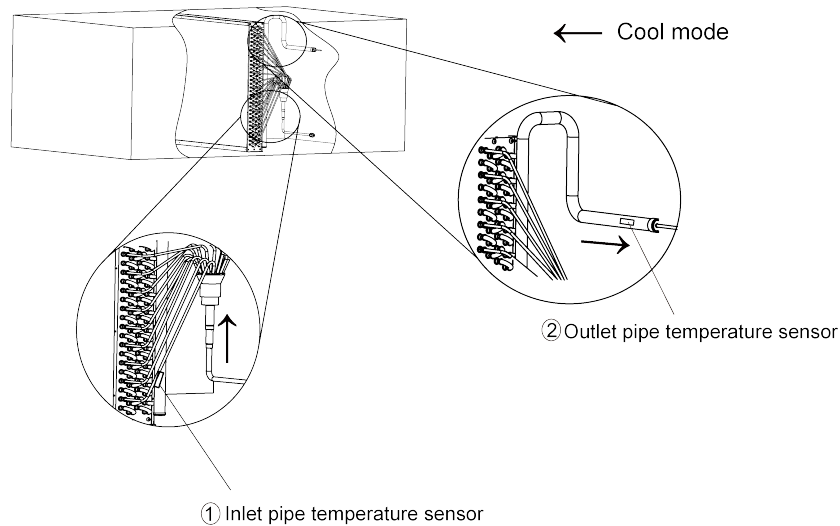

Fig.4.6.1

- ① Inlet pipe temperature sensor (Liquid Temperature sensor)
- ② Outlet pipe temperature sensor (gas Temperature sensor)

Installation of the temperature sensor cable:

- (1) The length of temperature sensor wire is 10m(393-3/4 inch).
- (2) Put the temperature sensor cable in an individual protective tube.
- (3) Apply stress release in the temperature sensor wire to prevent the temperature sensor wire from getting loose due to stress. Stress or looseness of temperature sensor wire will lead to poor contact and inaccuracy of temperature measuring. Fixation of the temperature sensor.

<b>NOTICE</b>	
<p>① Put the temperature sensor wire slightly down to avoid water accumulation on top of the temperature sensor.</p>	

**NOTICE**

- ② Keep the temperature sensor and air handling unit in good contact. Put the top of the temperature sensor on the air handling unit, because the top of temperature sensor is the most sensitive part. Please fixing the temperature sensor on the horizontal plane of copper tube (within  $\pm 30^\circ$ ), and make them close together.

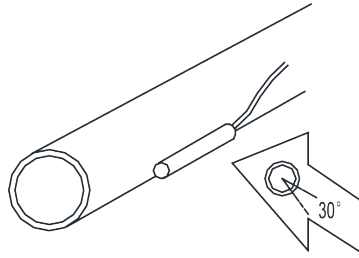

- ③ Fix the temperature sensor with insulating aluminum tape in order to ensure good heat transference.

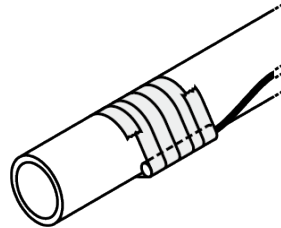

- ④ Cover the temperature sensor with rubber belt to prevent looseness of temperature sensor.

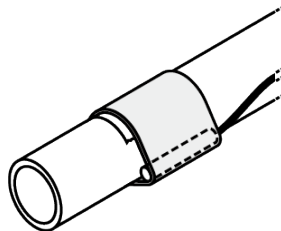

- ⑤ Use two wire ties to bind the temperature sensor securely.

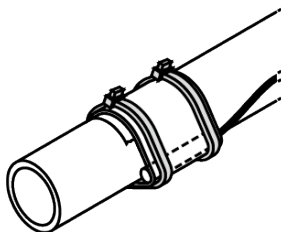

- ⑥ Wrap the temperature sensor with insulating trip.

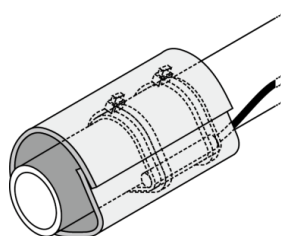

### 4.6.2 Air Temperature Sensor

The air temperature sensor can be installed in the space which needs temperature control, or the inlet scoop of air handling unit.

#### **NOTICE**

- |   |
|---|
| ① For connection to outdoor unit and to AHU-KIT unit: Pull the wires inside through the screw nut and close the nut firmly in order to ensure a good pull relieve and water protection. |
| ② The cables require an additional pull relief. Fixing the cable with the wire clamp.   |
| ③ The connection of temperature sensor requires enough space.   |

### 4.6.3 Installation of Temperature Sensor when Several AHU-KITs are in Parallel Connection with One AHU

When several AHU-KITs are in parallel connection with one AHU, all linkage AHU-KIT inlet pipes' and outlet pipes' temperature sensor must be installed at the position of corresponding pipeline of air handling unit. Install the ambient temperature sensor at the same position of air return outlet. Please refer to above installation method of single AHU-KIT temperature sensor. The installation diagram is as below:

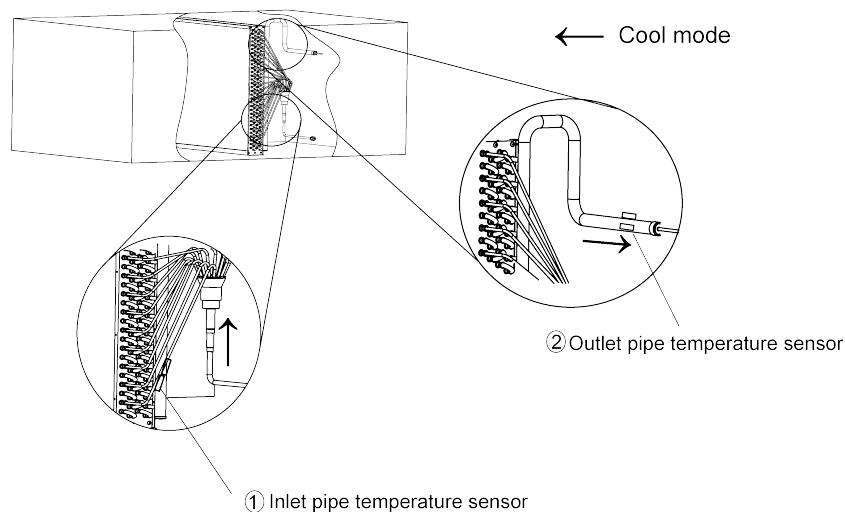

Fig.4.6.2

- ① Inlet pipe temperature sensor (Liquid Temperature sensor)
- ② Outlet pipe temperature sensor (Gas Temperature sensor)

### 4.7 Installation of Wired Controller

Please refer to User Manual of Wired Controller for the installation details.

#### **NOTICE**

When installation is finished, the unit must be tested and debugged before operation. Please refer to Instruction Manual of ODU for auto addressing and debugging details.

## 5 Wire Connection

<b>NOTICE</b>
① Units must be earthed securely, or it may cause electric shock.
② Please carefully read the wiring diagram before carry out the wiring work, incorrect wiring could cause malfunction or even damage the unit.
③ The capacity of power supply should be big enough.
④ The unit should be powered by independent circuit and specific socket.
⑤ The wiring should be in accordance with related regulations in order to ensure the units reliable running.
⑥ Install circuit breaker for branch circuit according to related regulations and electrical standards.
⑦ All wiring must use pressure terminal or single wire. Multi-twisted wire that connects directly to the wiring board may cause fire hazard.
⑧ Keep cable away from refrigerant piping, compressor and fan motor.
⑨ Do not alter the inner wires of air conditioner. Manufacturer does not assume responsibility for damage or abnormal operation due to this reason.
⑩ If the unit is installed in places with strong electromagnetic interference, it's recommended to use twin-twisted shield wire. During wire connection, please pay attention that the metal shield layer of the twin-twisted wire must be grounded (outer case) in order to prevent the unit from electromagnetic interference.
⑪ The communication wires should be separated from power cord and connection wire between indoor unit and outdoor unit.
⑫ The appliance shall be installed in accordance with national wiring regulations.
⑬ For security, it is suggested that the exposed wires of EXV and temperature sensors wrapped in insulated tubes for good isolation.

### 5.1 Connect Cables and Terminals of Wiring Board

#### (1) Connection of Wire and Patch Board Terminal (as shown in Fig.5.1.1)

- 1) Strip about 25mm(1 inch) insulation of the wire end by stripping and cutting tool.
- 2) Remove the wiring screws on the terminal board.
- 3) Shape the tail of wire into ring by needle nose plier, and keep the gauge of ring in accordance with screw.
- 4) Use the screwdriver for tightening the terminal.

#### (2) The connection of stranded wire (as shown in Fig.5.1.2)

- 1) Strip about 10mm(3/8 inch) insulation of the end of stranded wire by stripping and cutting tool.
- 2) Loosen the wiring screws on terminal board.
- 3) Insert the wire into the ring tongue terminal and tighten by crimping tool.
- 4) Use the screwdriver for tightening the terminal.

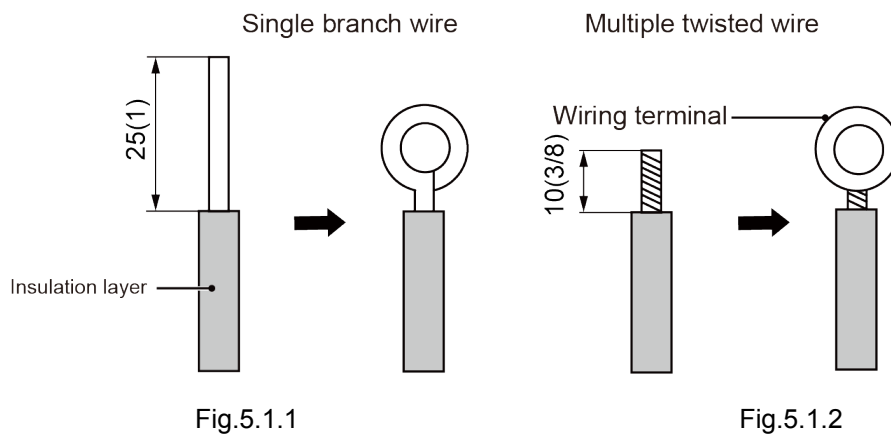

## 5.2 Power Cord Connection

### NOTICE

Each indoor unit must be installed with an independent circuit breaker for short-circuit protection and overload protection. In general, this circuit breaker is under close status.

During operation process, all indoor units and outdoor units in one system must be energized. Otherwise, the system can't operation normally.

Power supply of each indoor unit must be from the same source.

Power connection diagram for one AHU-KIT connected to one AHU:

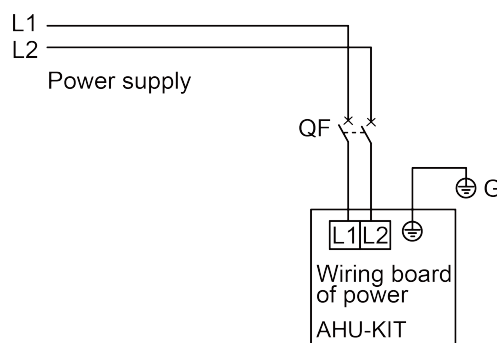

Fig.5.2.1

- (1) Detach the electric box lid.
- (2) Let the power cord pass through the wiring through-holes.
- (3) Connect the power cord to terminal "L1, L2, ⊕".
- (4) Fix the power cord with wiring clamp.

Power connection diagram for several AHU-KITs in parallel connection with one AHU:

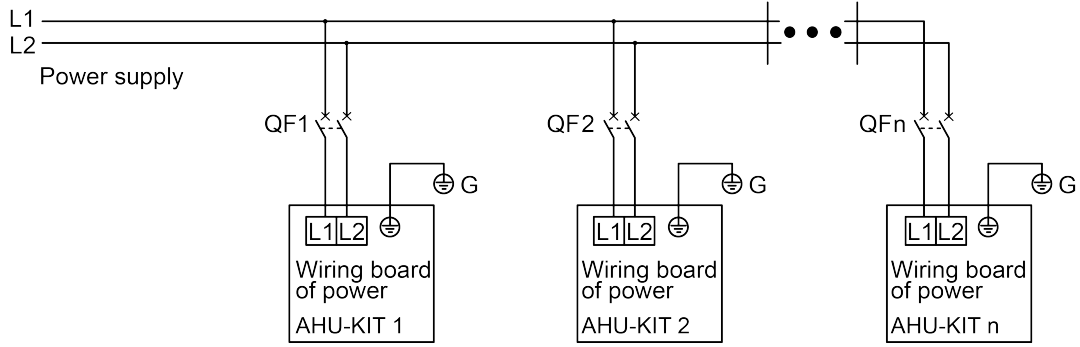



Fig.5.2.2

- (1) Detach the electric box lid.
- (2) Let the power cord pass through the wiring through-holes.
- (3) Connect the power cord to terminal “L1, L2, 

### 5.3 Connection of Communication Wire between Indoor Unit and Outdoor Unit (or Indoor Unit)

- (1) Detach the control box lid.
- (2) Let the Communication cable pass through the wiring through-holes.
- (3) Connect the communication wire to terminal D1 and D2 of indoor 4-bit wiring board, as shown in Fig.5.3.1.
- (4) Fix the communication cable with clamp of electric box.
- (5) For more reliable communication, make sure connect the terminal resistor to the most downstream IDU of the communication bus (terminal D1 and D2), as shown in Fig.5.3.2, terminal resistor is provided with each ODU.

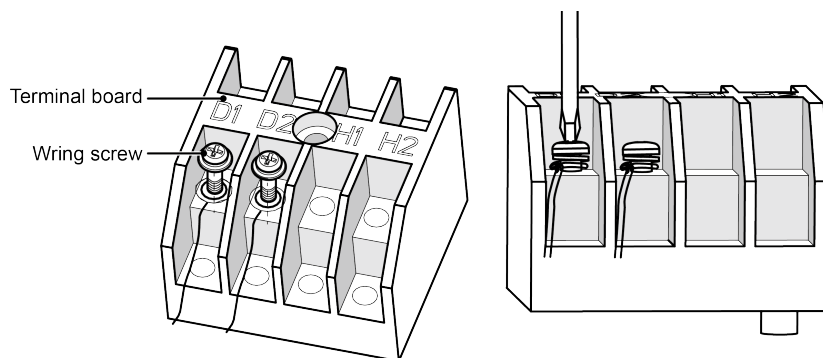
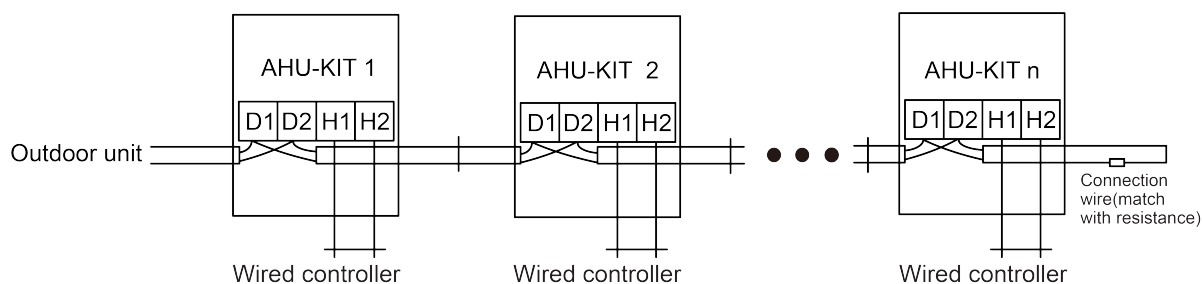

Fig.5.3.1



**NOTICE** AHU-KIT quantity n is according to the outdoor unit capacity.

Fig.5.3.2

## 5.4 Connect Communication Wire of Wired Controller

- (1) Open electric box cover of indoor unit.
- (2) Let the communication wire go through the rubber ring.
- (3) Connect the communication wire to terminal H1 and H2 of indoor 4-bit wiring board.
- (4) Fix the communication wire with wire clip on the electric box.
- (5) Wiring instructions of remote receiving light board and wired controller.

Fig.5.4 shows the installation of wired controller:

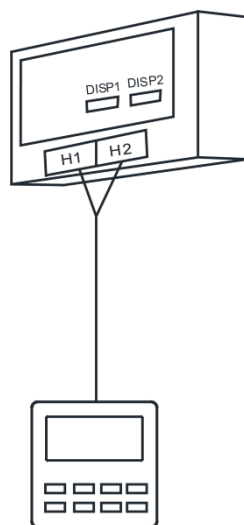

Fig.5.4

## 5.5 Illuminate for Connection of Wired Controller and Indoor Units

### (AHU-KIT) Network

- (1) Communication wire of indoor unit and outdoor unit (or indoor unit) is connected to D1, D2.
- (2) Wired controller is connected to H1, H2.
- (3) One indoor unit can connect two wired controllers that must be set as master one and slave one.

(4) One wired controller can control 16 indoor units in maximum at the same time (as shown in Fig.5.5).

<b>NOTICE</b>	
①	The type of indoor units must be the same if they are controlled by the same wired controller.
②	When the indoor unit is controlled by two wired controllers, the addresses of the two wired controllers should be different through address setting. Address 1 is for main controller; Address 2 is for slave controller. Detailed setting please refers to the instruction manual of wired controller.

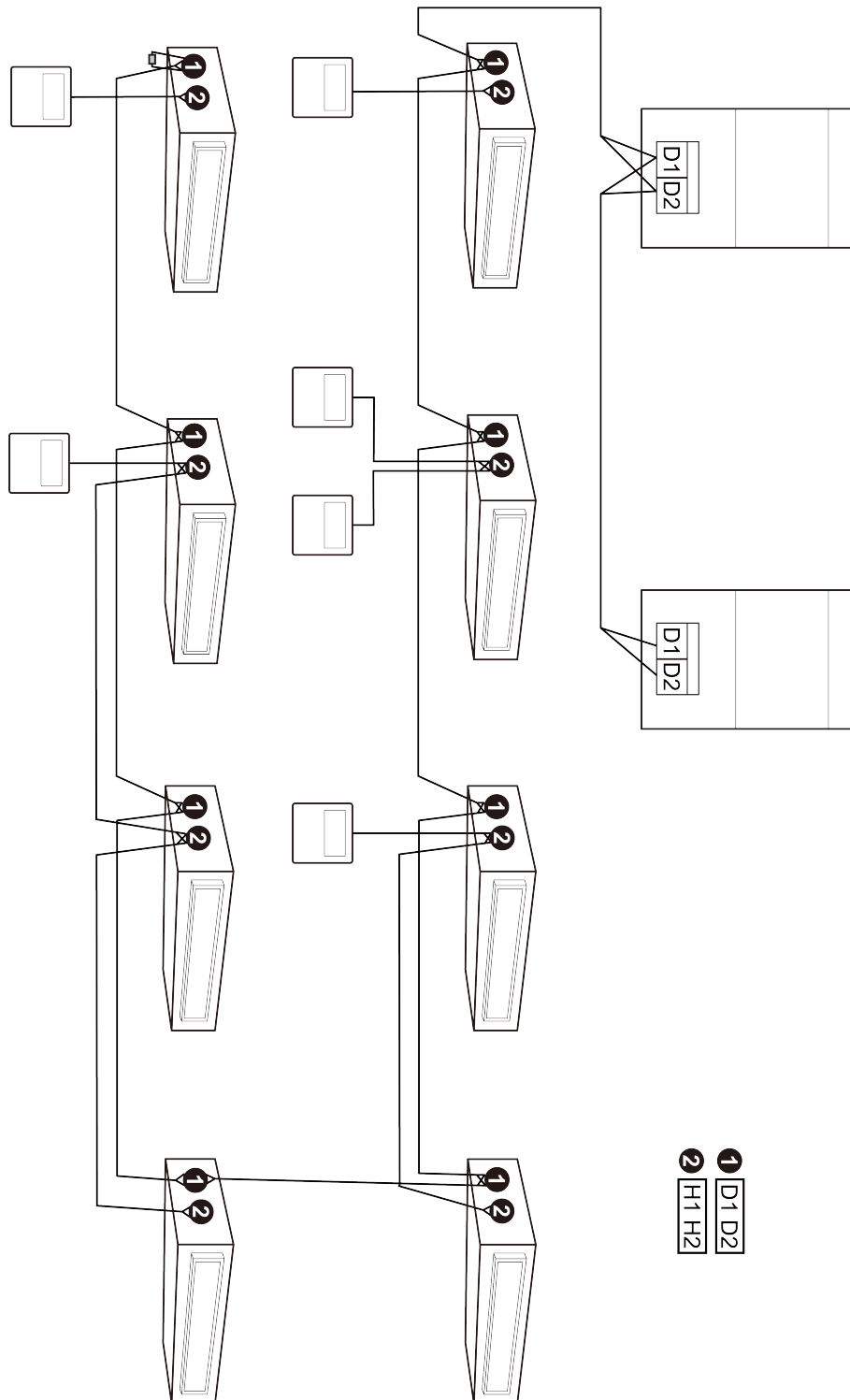

Fig.5.5



## 6 Function Setting

### 6.1 Statement on Linkage Function Setting

When several AHU-KITs are in parallel connection with one AHU, you must activate linkage function after installation for normal operation. Setting way is as below:

Step 1: Set group control IDU quantity

After making sure all AHU-KITs are energized, set AHU-KIT quantity through wired controller P14, detailed operation is as follows:

Under on or off status, press “Function” button for 5s to enter into the first level menu interface; Under parameter code “C00” status, (after pressing “Mode” button for three times press “Function” button for 5s to enter into the second level menu. The temperature area displays “P00”. Press “▲” and “▼” button can swing to the second level parameter code. Enter P14 engineer debugging interface, the top right corner of the interface will display “01”, which means the number of AHU-KIT under the control of wired controller is 1, short press “Mode”, and revise actual controlled AHU-KIT quantity through pressing “▲” and “▼” button, If two AHU-KITs are in parallel connection, please set 02, short press “Confirmed/Cancel” button, the setting is successful.

Step 2: Linage function startup setting. The operation is as below:

Operate it according to above operation to enter P53 engineer debugging interface, the top right corner of the interface will display “00”, which means AHU-KIT linkage function is invalid; short press “Mode”, and conduct revision through pressing “▲” and “▼” button, set “01”, which means AHU-KIT linkage function is valid, short press “Confirmed/Cancel” button, the setting is successful.

### 6.2 Fresh air Function Setting

#### 6.2.1 General Wire Controller

When it needs the fresh air indoor unit control, set the fresh air function with wired controller according to below method:

When the AHU adapter is energized, set the fresh air function with wired controller P60 by operation method as below:

Under on or off status, press “Function” button for 5s to enter into the first level menu interface. Under parameter code “C00” status, (after pressing “Mode” button for three consecutive times.) press “Function” button for 5s again to enter into the second level menu. The temperature area

displays “P00”. Press “▲” and “▼” buttons can switch to the second level parameter code. After entering into P60 engineering debugging interface, the top right corner of interface will display “00”, which indicates it will control according to normal indoor unit. Short press “Mode” button and then press “▲” and “▼” buttons to modify it. Setting is “01”, which indicates fresh air is valid. Short press “Confirm/Cancel” button , the setting is successful.

### **NOTICE**

When setting the fresh air function, the air outlet temperature sensor must be installed.

## 6.2.2 Special Wire Controller

When the AHU adapter is energized, set the fresh air function with wired controller XE70-33/H as below:

### Step 1: Set fresh air function

Under on or off status, press “☰” to enter into the menu page, and then select “set” to enter into the setting page; in the setting interface, select “project set” to enter into the parameter setting page.

Press “^” or “v” button to switch the option, press and hold the button can switch quickly; Press “<” or “>” button to turn the page.

When selecting the right icon “●” or “○”, press “☰” button to turn on or turn off the corresponding.

In the parameter setting page select “Fresh Air Control Function” to enter into the page, the interface will display “0”, which indicates it will control according to normal indoor unit. Setting is “1”, which indicates fresh air is valid.

### Step 2: Set the lowest air outlet temperature

In the parameter setting page select “Lowest Air Outlet Temperature Can Be Set” to enter into the page, the default display is “16°C(60.8°F)”, which can be set to “13°C(55.4°F)”.

### **NOTICE**

- ① The Wired Controller XE70-33/H needs engineering customization.
- ② For specific settings, please refer to the technical service manual or consult a technical staff.

## 6.3 Selection of Controller

### 6.3.1 Introduction to Functions

AHU-KIT adapter can be controlled via Gree wired controller, and can also be controlled via the third party controller by adjusting dial code, which can realize ON/OFF control, mode setting, temperature adjustment, feedback of unit operating status, etc.

### 6.3.2 Selection of Controller

AHU-KIT adapter can be controlled via Gree wired controller or the third party controller. Select the type of controller according to the first digit of "S2" dial code in the mainboard, for specific settings are as below:

S2				Type of controller
1	2	3	4	
0	0	0	0	Gree wired controller
1	0	0	0	Third party controller

Correctly dial the code switch to the right position, it is not allowed to dial to the middle position. Dialing the switch to "ON" direction refers to "0", and the objective direction refers to "1", as shown below (NOTICE: the black part is the dial lever):

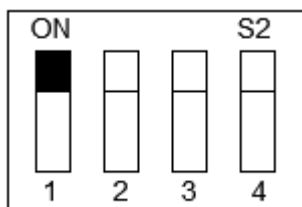

It means it has connected  
to Gree wired controller

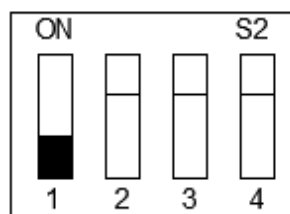

It means it has connected  
to the third party controller

Fig.6.3

### NOTICE

- ① Power supply must be cut off before adjusting any dial codes on the mainboard. Only when the adjustment is done can the power supply be reconnected, otherwise it may cause electric shock or invalid adjustment;
- ② Under the control mode of Gree wired controller, only control signal from Gree wired controller can be received, control signal of the third party controller cannot be received;
- ③ Under the control mode of the third party controller, only control signal from the third party's controller can be received, control signal of Gree wired controller cannot be received;

- ④ Even though the third party controller is selected, engineering setting of AHU-KIT adapter still needs to be set by Gree wired controller, such as “linkage function”, “fresh air function”, etc.;
- ⑤ When several sets of AHU-KIT adapter are simultaneously used, and one controller needs to control several sets of unit and the controller is the third party controller, the first bit of S2 dial code of adaptor for the third party’s controller is adjusted as “1”, and the first bit of S2 dial code of other adaptor is adjusted as “0” and connected to Gree wired controller.

### 6.3.3 Connection between the Third Party Controller and AHU-KIT Adapter

AHU-KIT adapter is connected with the third party controller via dry contact analog quantity signal interface to realize control of unit, feedback of operating status and error protection, etc.

#### (1) Definition of interfaces

##### 1) Signal from the third party controller to AHU-KIT adapter

Function	Type of interface	Wiring board	Wiring number	Description of signal
ON/OFF	Dry contact	XT5	4、5	When it is connected, it means ON; when it is disconnected, it means OFF
Cooling mode	Dry contact	XT5	6、7	When it is connected, it means cooling; when it is disconnected, it means not cooling
Heating mode	Dry contact	XT5	8、9	When it is connected, it means heating; when it is disconnected, it means not heating
Air supply mode	Dry contact	XT5	10、11	When it is connected, it means air supply; when it is disconnected, it means not air supply
Feedback of AHU error status	Dry contact	XT4、XT5	XT4(1)、XT5(1)	When it is connected, it means AHU has no error; when is it disconnected, it means AHU has error
Temperature setting	Analog voltage signal DC (0-10V)	XT5	2(+), 3(-)	①Corresponding set temperature for input DC 0-10V is defaults to 16~30°C(60.8~86°F) (please see the setting of signal for temperature control) ②Corresponding set temperature of 13~27°C (55.4~80.6°F), it is necessary to specify the setting of the wire controller XE70-33/H to achieve

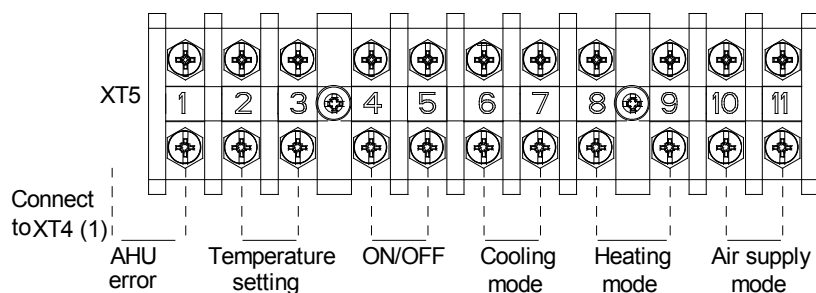

Fig.6.3.1

## 2) Signal from AHU-KIT adapter to the third party controller

Function	Type of interface	Wiring board	Wiring number	Description of signal
Operating status of AHU-KIT	Dry contact	XT4	2、3	When it is connected, it means the AHU-KIT is on; when it is disconnected, it means the AHU-KIT is off. (The input terminal cannot be connected to strong power and recommended voltage is 24V or less.)
Defrosting status of unit	Dry contact	XT4	4、5	When it is connected, it means the unit is in defrosting status; when it is disconnected, it means the unit is not in defrosting status. (The input terminal cannot be connected to strong power and recommended voltage is 24V or less.)
Error status of ODU and AHU-KIT	Dry contact	XT4	6、7	When it is connected, it means the unit has error; when it is disconnected, it means the unit is normal. (The input terminal cannot be connected to strong power and recommended voltage is 24V or less.)

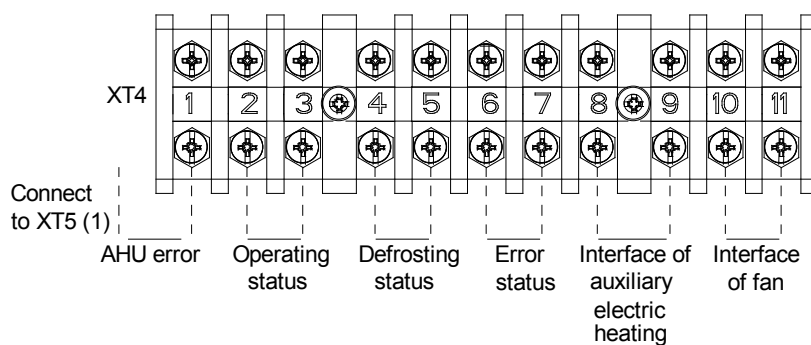

Fig.6.3.2

## (2) Definition for input signal of temperature setting

AHU-KIT adapter provides the relation of direct and inverse ratio between DC 0-10V input voltage signals of and the corresponding set temperature. Select the direct and inverse ratio relation between the input voltage and the corresponding set temperature according to the second bit of “S2” dial code on the mainboard. The specific settings are as below:

S2				Relation between input voltage and set temperature
1	2	3	4	
1	0	0	0	Direct ratio between input voltage and set temperature
1	1	0	0	Inverse ratio between input voltage and set temperature

## 1) Setting of dial code

Correctly dial the code switch to the right position, it is not allowed to dial to the middle position. Dialing the switch to “ON” direction refers to “0”, and the objective direction refers to “1”, as shown below (NOTICE: the black part is the dial lever):

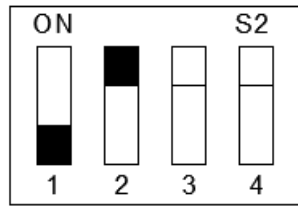

Direct ratio between input voltage and set temperature

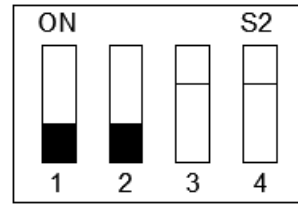

Inverse ratio between input voltage and set temperature

Fig.6.3.3

2) Definition of input voltage signal

When the second bit of “S2” dial code is dialed to “0”, that is, the input voltage and set temperature is direct ratio, then the relation between input voltage and set temperature is as below:

Analog quantity input DC 0~10V			Set temperature (°C) Cooling	Set temperature (°C) Heating
Standard value (V)	Voltage range (V)			
	Minimum value	Maximum value		
0	0≤	<0.1	Invalid value	Invalid value
0.5	0.1≤	≤1.15	Default value	Default value
1.5	1.35≤	≤1.65	T <sub>lowest</sub> +0	T <sub>lowest</sub> +0
2	1.85≤	≤2.15	T <sub>lowest</sub> +1	T <sub>lowest</sub> +1
2.5	2.35≤	≤2.65	T <sub>lowest</sub> +2	T <sub>lowest</sub> +2
3	2.85≤	≤3.15	T <sub>lowest</sub> +3	T <sub>lowest</sub> +3
3.5	3.35≤	≤3.65	T <sub>lowest</sub> +4	T <sub>lowest</sub> +4
4	3.85≤	≤4.15	T <sub>lowest</sub> +5	T <sub>lowest</sub> +5
4.5	4.35≤	≤4.65	T <sub>lowest</sub> +6	T <sub>lowest</sub> +6
5	4.85≤	≤5.15	T <sub>lowest</sub> +7	T <sub>lowest</sub> +7
5.5	5.35≤	≤5.65	T <sub>lowest</sub> +8	T <sub>lowest</sub> +8
6	5.85≤	≤6.15	T <sub>lowest</sub> +9	T <sub>lowest</sub> +9
6.5	6.35≤	≤6.65	T <sub>lowest</sub> +10	T <sub>lowest</sub> +10
7	6.85≤	≤7.15	T <sub>lowest</sub> +11	T <sub>lowest</sub> +11
7.5	7.35≤	≤7.65	T <sub>lowest</sub> +12	T <sub>lowest</sub> +12
8	7.85≤	≤8.15	T <sub>lowest</sub> +13	T <sub>lowest</sub> +13
8.5	8.35≤	≤8.65	T <sub>lowest</sub> +14	T <sub>lowest</sub> +14
9.5	8.85≤	≤10	Default value	Default value

When the second bit of “S2” dial code is adjusted to “1”, that is, input voltage and set temperature is inverse ratio, then the relation between input voltage and set temperature is as below:

Analog quantity input DC 0~10V			Set temperature (°C) Cooling	Set temperature (°C) Heating
Standard value (V)	Voltage range (V)			
	Minimum value	Maximum value		
0	0≤	<0.1	Invalid value	Invalid value
0.5	0.1≤	≤1.15	Default value	Default value
1.5	1.35≤	≤1.65	T <sub>lowest</sub> +14	T <sub>lowest</sub> +14
2	1.85≤	≤2.15	T <sub>lowest</sub> +13	T <sub>lowest</sub> +13
2.5	2.35≤	≤2.65	T <sub>lowest</sub> +12	T <sub>lowest</sub> +12
3	2.85≤	≤3.15	T <sub>lowest</sub> +11	T <sub>lowest</sub> +11

Analog quantity input DC 0~10V			Set temperature (°C) Cooling	Set temperature (°C) Heating
Standard value (V)	Voltage range (V)			
	Minimum value	Maximum value		
3.5	$3.35 \leq$	$\leq 3.65$	$T_{\text{lowest}} + 10$	$T_{\text{lowest}} + 10$
4	$3.85 \leq$	$\leq 4.15$	$T_{\text{lowest}} + 9$	$T_{\text{lowest}} + 9$
4.5	$4.35 \leq$	$\leq 4.65$	$T_{\text{lowest}} + 8$	$T_{\text{lowest}} + 8$
5	$4.85 \leq$	$\leq 5.15$	$T_{\text{lowest}} + 7$	$T_{\text{lowest}} + 7$
5.5	$5.35 \leq$	$\leq 5.65$	$T_{\text{lowest}} + 6$	$T_{\text{lowest}} + 6$
6	$5.85 \leq$	$\leq 6.15$	$T_{\text{lowest}} + 5$	$T_{\text{lowest}} + 5$
6.5	$6.35 \leq$	$\leq 6.65$	$T_{\text{lowest}} + 4$	$T_{\text{lowest}} + 4$
7	$6.85 \leq$	$\leq 7.15$	$T_{\text{lowest}} + 3$	$T_{\text{lowest}} + 3$
7.5	$7.35 \leq$	$\leq 7.65$	$T_{\text{lowest}} + 2$	$T_{\text{lowest}} + 2$
8	$7.85 \leq$	$\leq 8.15$	$T_{\text{lowest}} + 1$	$T_{\text{lowest}} + 1$
8.5	$8.35 \leq$	$\leq 8.65$	$T_{\text{lowest}} + 0$	$T_{\text{lowest}} + 0$
9.5	$8.85 \leq$	$\leq 10$	Default value	Default value

**NOTICE**

① If the AHU-KIT adapter is installed in the position with strong electromagnetic interference, the voltage signal may be impacted, which should be shielded to ensure the accuracy of input voltage signal.

② When the AHU-KIT detects that the corresponding set temperature of voltage is "default value":

If the unit is under cooling mode, the default set temperature is  $26 + (T_{\text{lowest}} - 16) \text{ } ^\circ\text{C}$  [ $78.8 + (T_{\text{lowest}} - 60.8) \text{ } ^\circ\text{F}$ ].

If the unit is under heating mode, the default set temperature is  $20 + (T_{\text{lowest}} - 16) \text{ } ^\circ\text{C}$  [ $68 + (T_{\text{lowest}} - 60.8) \text{ } ^\circ\text{F}$ ].

If the unit is under air supply mode, the default set temperature is  $26 + (T_{\text{lowest}} - 16) \text{ } ^\circ\text{C}$  [ $78.8 + (T_{\text{lowest}} - 60.8) \text{ } ^\circ\text{F}$ ].

③ Input voltage should not be over 10V, otherwise it may damage the controller.

④ When set to the fresh air control function, the final set temperature needs to be adjusted according to "  $T_{\text{lowest}}$  ", "  $T_{\text{lowest}}$  " can be set by the specific wired controller. The setting value of "  $T_{\text{lowest}}$  " is  $13^\circ\text{C}$  ( $55.4^\circ\text{F}$ ),  $16^\circ\text{C}$  ( $60.8^\circ\text{F}$ ) and the default is  $16^\circ\text{C}$  ( $60.8^\circ\text{F}$ ).

### 3) Diagram for integrated connection of system

When on AHU adapter connects to one set of air conditioner and adopts the third party controller, the connection is shown as below:

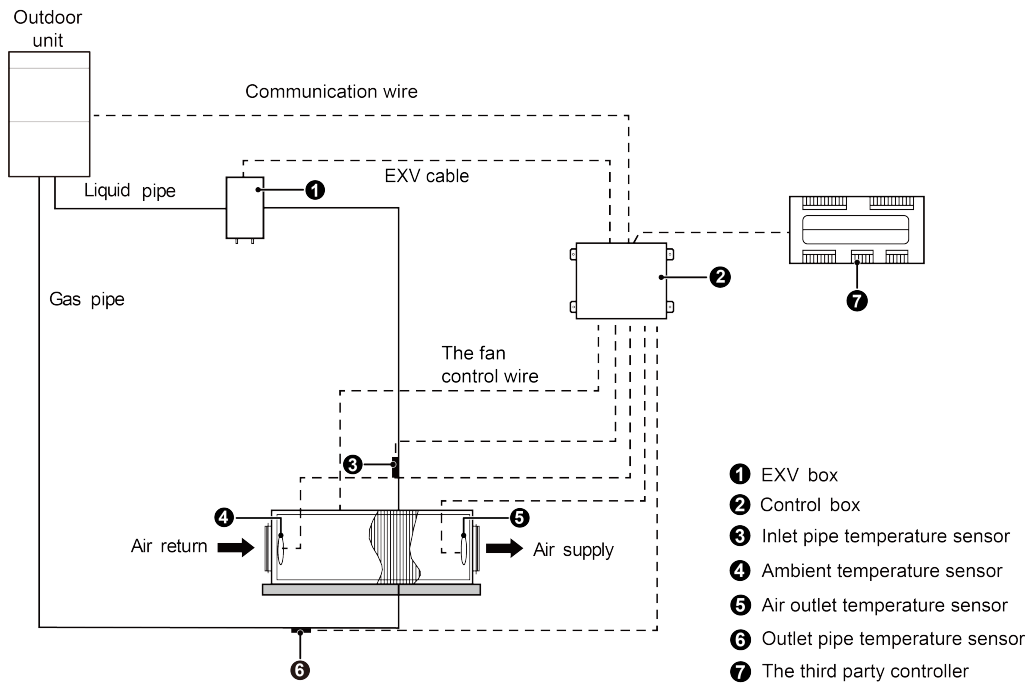

Fig.6.3.4

When several sets of AHU adapters connect in parallel and connect to one set of air conditioner, the diagram is shown as below:

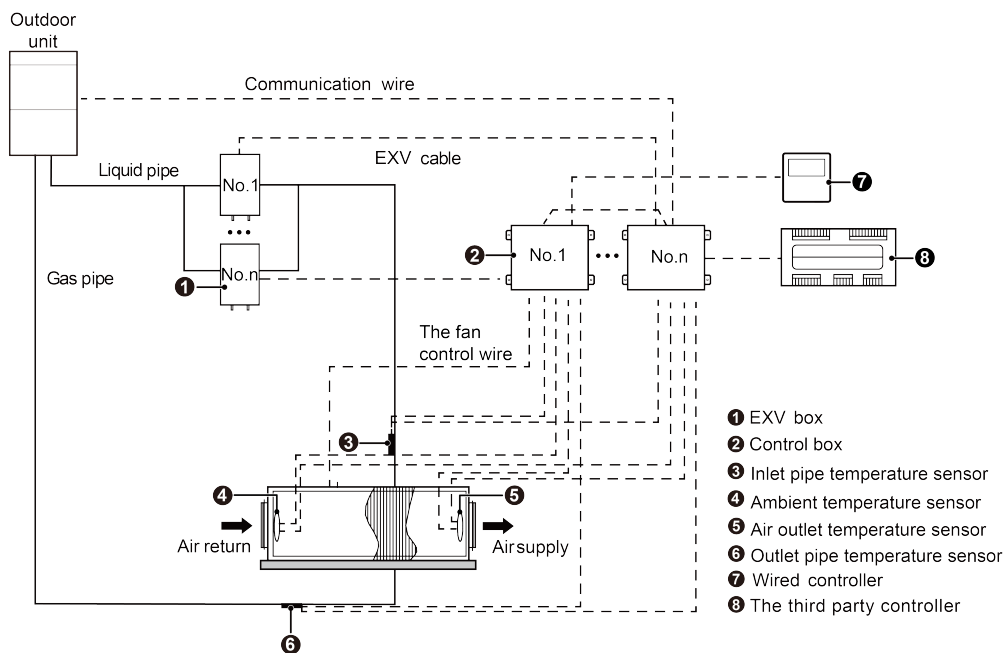

Fig.6.3.5

**NOTICE**

- ① Length of connection wire between the third party controller to AHU-KIT adapter should not be over 15m(590-1/2 inch).
- ② When several sets of AHU-KIT adapter connect in parallel and adopts the third party



controller, the first bit of S2 dial code of adapter connected to the third party controller is adjusted to “1”, and the first bit of S2 dial code of the other adapters is adjusted to “0” and connect to Gree wired controller.

- ③ When AHU-KIT adapter adopts the third party controller, AHU-KIT adapter needs to connect to Gree wired controller while setting the master IDU. The methods for setting the master IDU through the wired controller are as follows:

Step 1: Set an IDU to power-off status.

Step 2: Press and hold the "MODE" button on the wired controller for more than five seconds.

Step 3: Check whether the setting is successful. If it is, "MASTER" on the wired controller will be on. Otherwise, repeat steps 1 and 2.

## 7 Operation and Maintenance

### 7.1 Before Operation

#### **NOTICE**

- |   |
|---|
| <p>① Before initiating operation, please read the operation manuals of outdoor unit, AHU-KIT unit and the air handling unit carefully.</p> <p>② Refer to the installation manuals of the outdoor unit, AHU-KIT unit and the remote controller about settings of unit.</p> |
|---|

### 7.2 Test Operation

Before executing "test operation" as well as before operating the unit, you must check the following:

- (1) Refer to the section of "For the following items, take special care during construction and check after installation is finished".
- (2) Ensure the construction of refrigerant piping, drain piping and electric wiring are finished.
- (3) Check everything written in the installation manuals of the outdoor unit, AHU-KIT unit and the air handling unit.
- (4) Open the gas side stop valve.
- (5) Open the liquid side stop valve.

Executing the test operation:

- (1) Referring to the manuals of the outdoor unit and the air handling unit.
- (2) Confirm that the fan of the air handling unit is ON.

## 7.3 Routine Maintenance

<b>NOTICE</b>	
①	Only a qualified service person is allowed to perform maintenance.
②	Before obtaining access to terminal devices, all power supply circuits must be interrupted.
③	Water or detergent may deteriorate the insulation of electronic components and result in burn-out of these components.
④	Stand at solid table when cleaning the unit.
⑤	Do not clean the unit with hot water whose temperature is higher than 45°C(113°F) to prevent fade or deformation.
⑥	Clean the filter with a wet cloth dipped in neutral detergent.
⑦	Please contact after-sales service staff if there is abnormal situation.

### 7.3.1 Maintenance before the Seasonal Use

- (1) Check if the air inlet and air outlet of indoor and outdoor unit are blocked.
- (2) Check if securely grounded.
- (3) Check if all the power cord and communication cable are securely connected.
- (4) Check if any error code displayed after energized.

### 7.3.2 Maintenance after the Seasonal Use

- (1) Set the unit in fan mode for half a day in a sunny day to dry the inner part of unit.
- (2) When the unit won't be used for a long time, please cut off power supply for energy saving; the characters on the wired controller screen will disappear after cutting off the power supply.

## 7.4 Disposal Requirements

Dismantling of the unit, treatment of the refrigerant, of oil and of other parts must be done in accordance with relevant local and national legislation.

## 8 Table of Error Codes for Indoor Unit

Error Code	Content	Error Code	Content	Error Code	Content
L0	Indoor Unit Error	LA	Indoor Units Incompatibility Error	d9	Jumper Cap Error
L1	Indoor Fan Protection	LH	Low Air Quality Warning	dA	Indoor Unit Network Address Error
L2	E-heater Protection	LC	ODU-IDU Incompatibility Error	dH	Wired Controller PCB Error
L3	Water Full Protection	d1	Indoor Unit PCB Error	dC	Capacity DIP Switch Setting Error.
L4	Wired Controller Power Supply Error	d3	Ambient Temperature Sensor Error	dL	Indoor Unit CO <sub>2</sub> Sensor Error
L5	Freeze Protection	d4	Inlet Pipe Temperature Sensor Error	dE	Capacity DIP Switch Setting Error.
L7	No Master Indoor Unit Error	d6	Outlet Pipe Temperature Sensor Error	db	Special Code: Field Debugging Code
L8	Power Insufficiency Protection	d7	Humidity Sensor Error	C0	Communication Error
L9	Quantity Of Group Control Indoor Units Setting Error	d8	Water Temperature Sensor Error	AJ	Filter Cleaning Reminder
yJ	No Model Setting Signal Wire	yP	Multi-Model Conflict	yU	No Temperature Setting Signal Wire
o1	Low Bus bar Voltage of Indoor Unit	o2	High Bus bar Voltage of Indoor Unit	o3	IPM Module Protection of Indoor Unit
o4	Failure Startup of Indoor Unit	o5	Overcurrent Protection of Indoor Unit	o6	Current Detection Circuit Malfunction of Indoor Unit
o7	Desynchronizing Protection of Indoor Unit	o8	Communication Malfunction of Indoor Unit's Drive	o9	Communication Malfunction of Main Mater of Indoor Unit
oA	High Temperature of Indoor Unit's Module	ob	Malfunction of Temperature Sensor of Indoor Unit's Module	oC	Charging Circuit Malfunction of Indoor Unit
o0	Other Drive Malfunction	db	Special Code: Field Debugging Code		

## 9 Troubleshooting

If your air conditioner is not working well, please check the following table first before asking for service:

Phenomenon	Troubleshooting
The unit can't start.	<ul style="list-style-type: none"> <li>① No power supply.</li> <li>② Circuit breaker is tripped because of current leakage.</li> <li>③ Circuit voltage is too low.</li> <li>④ ON/OFF key sets at the stop position.</li> <li>⑤ Failure in control system.</li> </ul>
The unit stops after running for a while.	<ul style="list-style-type: none"> <li>① Obstacle in front of the condenser.</li> <li>② Abnormal operation of the control system.</li> <li>③ Outdoor temperature is higher than 43°C(109°F) when cooling mode is used.</li> </ul>
Poor cooling effect.	<ul style="list-style-type: none"> <li>① Air filter is dirty or blocked.</li> <li>② Too many heating sources or people in the room.</li> <li>③ Doors or windows are open.</li> <li>④ Obstacle at the air intake and outlet of the unit.</li> <li>⑤ Setting temperature is too high or refrigerant is insufficient (e.g. refrigerant leakage).</li> <li>⑥ Poor performance of the indoor temperature sensor.</li> </ul>
Poor heating effect.	<ul style="list-style-type: none"> <li>① Air filter is dirty or blocked.</li> <li>② Doors or windows are open.</li> <li>③ Wrong temperature setting (too low).</li> <li>④ Refrigerant leakage.</li> <li>⑤ Outdoor temperature is lower than -5°C(23°F).</li> <li>⑥ Abnormal operation of the control system.</li> </ul>
Indoor fan doesn't start up during heating.	<ul style="list-style-type: none"> <li>① Improper location of tube sensor.</li> <li>② The tube sensor inserts not well.</li> <li>③ The wiring of tube sensor is broken.</li> <li>④ Electricity leakage of capacitor.</li> </ul>

### **NOTICE**

If air conditioner still fails to work normally after checking and handling as described above, please stop using it immediately and contact local service center for assistance.

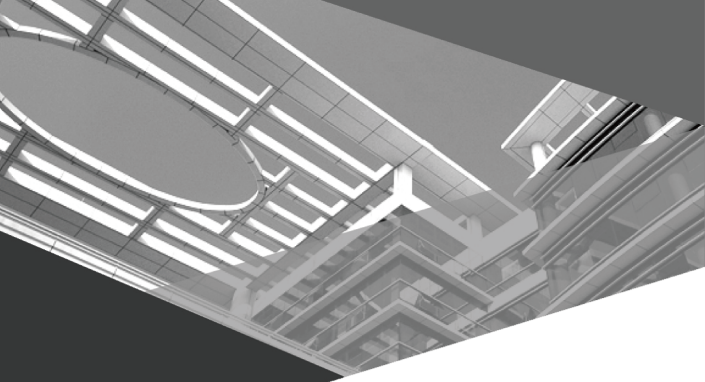

**GREE ELECTRIC APPLIANCES, INC. OF ZHUHAI**

Add: West Jinji Rd, Qianshan, Zhuhai, Guangdong, China, 519070

Tel: (+86-756) 8522218

Fax: (+86-756) 8669426

E-mail: [global@cn.gree.com](mailto:global@cn.gree.com) [www.gree.com](http://www.gree.com)



600005063076