

Air Conditioner Disconnect Box Fusible

Models: LBMDC-F

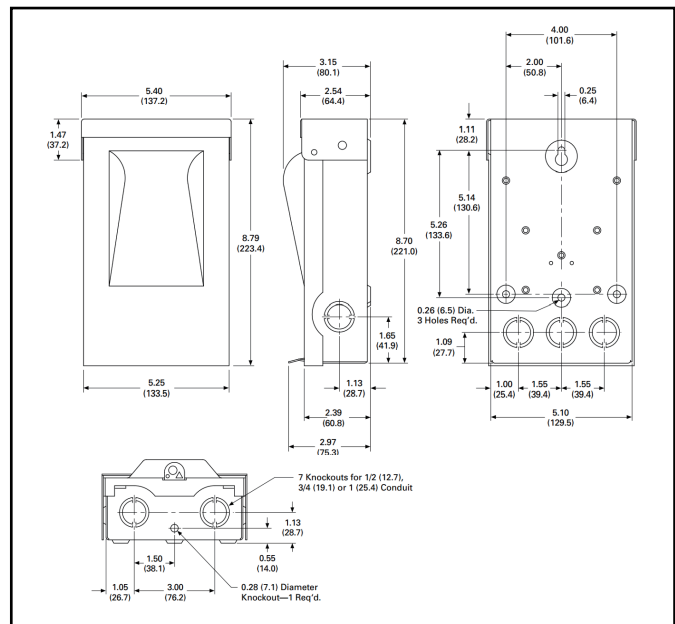
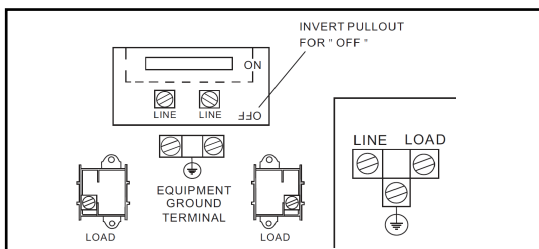

General Description

- UL Certified
- The enclosure is constructed of galvanized steel finished with light gray powder coating for durable use.
- The disconnect box is to disconnect the power source of air conditioner or other devices.
- The disconnect box provides a visible disconnecting means to prevent personal from getting shock when performing maintenance or installation.
- With a locking plate in the front, the disconnect box can be locked to prevent unauthorized operation.
- Protective shield can not be removed unless the Pull-out handle is removed, disconnecting the power.
- Pull-out handle can be stored in the compartment in the OFF position to prevent being misplaced.
- Optional Fusible and Non-fusible design available.

Air Conditioner Disconnect Box Fusible**Models: LBMDC-F**

Parts	Conductor	Rated AMP	Fusible	Rated HP		Package
				120V	240V	
LBMDC-F-30	#14-3	30	Yes	STD. 0.5/MAX. 2	STD. 1.5/MAX. 3	6/Carton
LBMDC-F-60	#14-3	60	Yes	STD. 1.5/MAX. 3	STD. 3/MAX. 10	6/Carton