

Bracket with Cross Bar L Shape-A

Models: LBBC-A

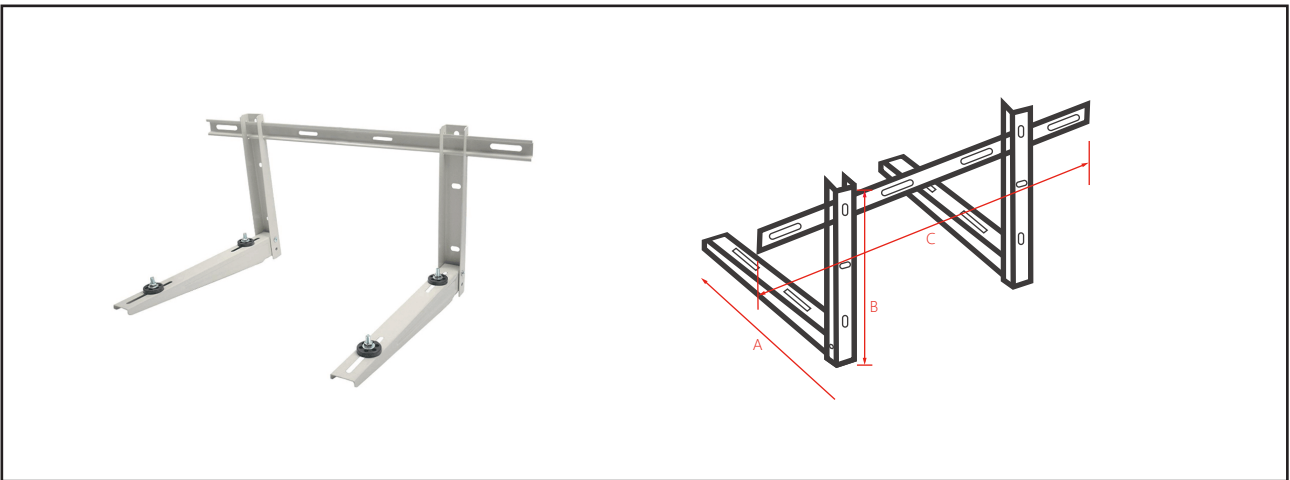

Model No.	AXBXC (inch)	Thickness (mm)	N.W(lb)	Loading Capacity (lb)
LBBC-A1	19-45/64 x 14-19/64 x 30-1/2	1/16	7.7	265
LBBC-A2	21-39/64 x 17-45/64 x 33-1/2	5/64	9.7	350

General Description

The LBBC-A wall brackets with cross bar are designed to mount a mini-split air conditioner outdoor unit on a suitable wall or structure and keep the equipment off ground. The LBBC-A consists of two independently mounted wall brackets and a cross bar with a polyester powder coating finishing for corrosion protection. Four rubber vibration absorber are included for vibration and noise elimination.

Bracket with Cross Bar L Shape-A

ASSEMBLY INSTRUCTION

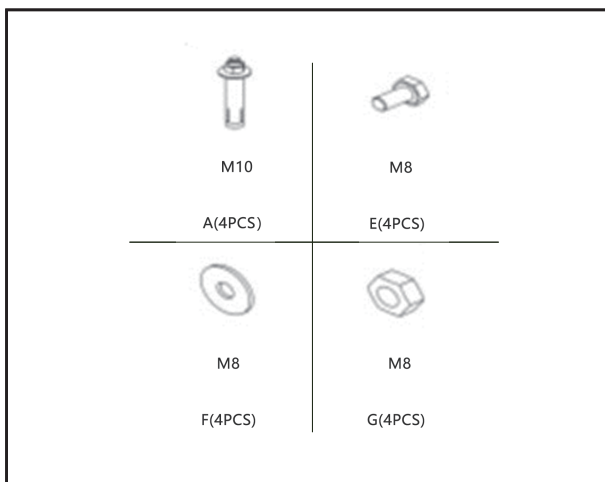

LBBC-A wall bracket with cross bar is a foldable bracket, L shape brackets are pre-assembled for easy installation.

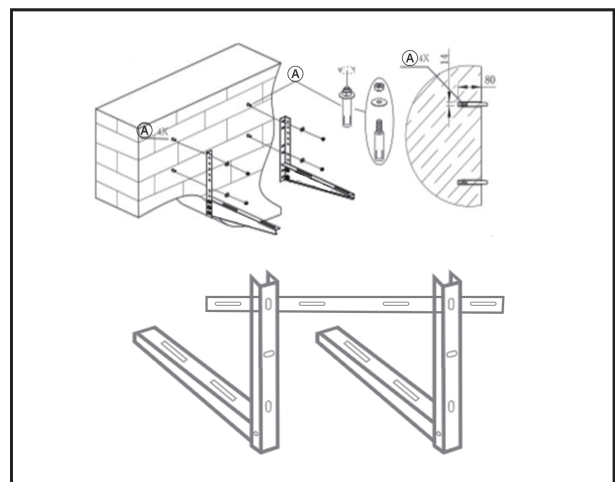

Make sure the chosen installation location meets with specified requirements and wall design and construction is suitable and strong enough to hold the brackets and the associated equipment loads. Anchors and related mounting hardware are provided.
