

Gravity Louver

Models: LBGL

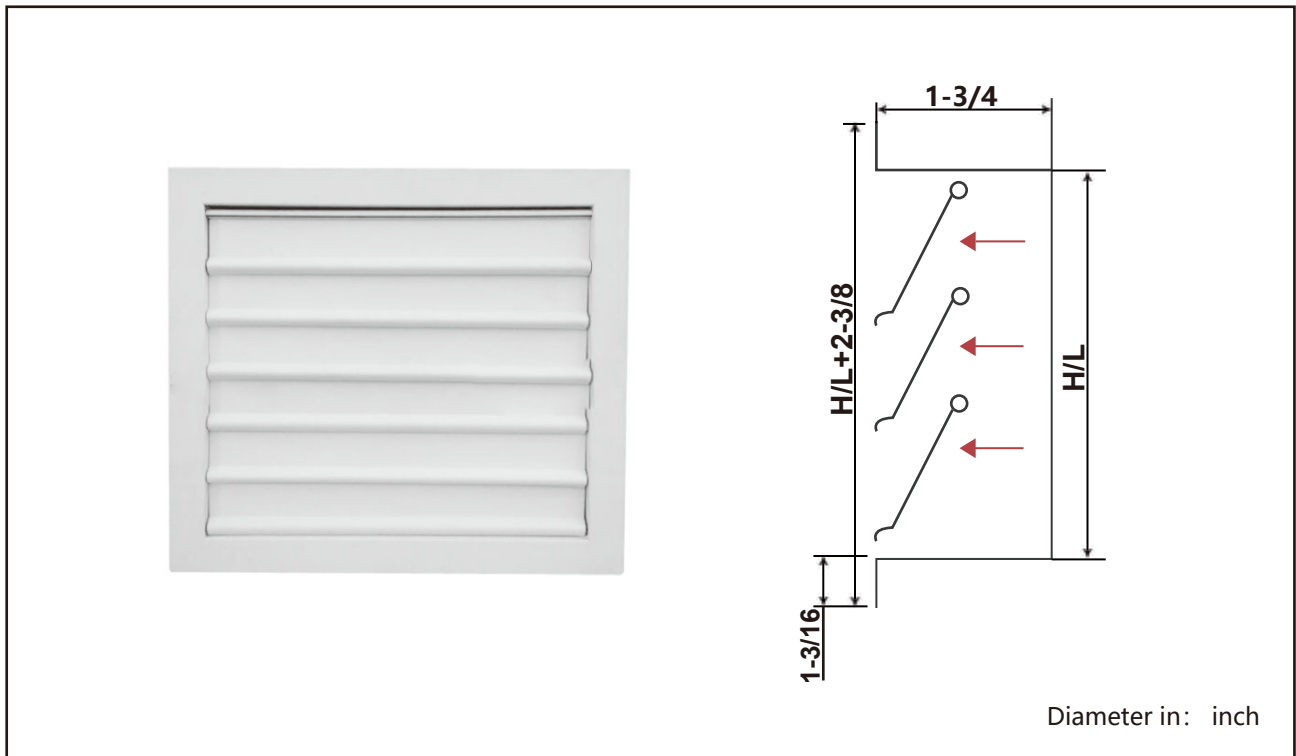

General Description

- Gravity louver is used for air extraction and automatic closing of duct when the fan is switched off.
- Gravity louver consists of a frame and movable plates mounted horizontally one above another.
- Gravity louver should be installed when blades facing downward.

Gravity Louver

Standard Finish: White Powder Coating.

Optional Finish: Powder Coating with customized color, or anodized.

Standard Size H/L (in)	Air Volume (cfm)
6 x 6	110
8 x 8	200
10 x 10	320
12 x 12	490
14 x 14	660
16 x 16	870
18 x 18	1240
20 x 18	1630
22 x 22	2110
24 x 24	2640
V=9.84 ft/s	